

série engrenagens
gear couplings series
serie engranajes

www.tecnongroup.com

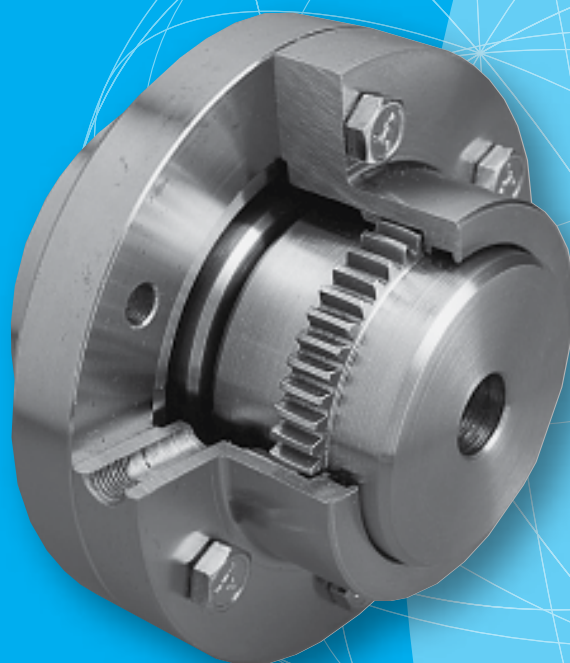

TECNON
Revolución **continua**



ACOPLAMENTOS DE ENGRENAGENS **POR** **Características**
ACOPLAMIENTOS DE ENGRANAJES **ESP** **Características**
GEAR COUPLINGS **ENG** **Features**

Acoplamentos flexíveis devem possuir três funções básicas:

1. Acoplar fisicamente dois eixos rotativos para uma eficiente transmissão de potência, transferindo o torque de um eixo ao outro, diretamente e com velocidade constante.
2. Compensar todos os tipos de desalinhamento entre os eixos, conectando-os sem induzir a fadiga, cargas anormais nos equipamentos do acionamento e sem perda significativa de potência.
3. Compensar os movimentos radiais ou axiais nos eixos acoplados, prevenindo-os de esforços excessivos transmitidos de um a outro, para girar na posição normal.

Três tipos de desalinhamento devem ser efetivamente absorvidos por um acoplamento flexível.

1. Desalinhamento paralelo: As linhas de centro dos eixos estão paralelas, mas não na mesma reta.
2. Desalinhamento angular: As linhas de centro dos eixos se intercedem no ponto central do acoplamento, mas não na mesma reta.
3. Desalinhamento combinado (angular e paralelo): As linhas de centro dos eixos não se encontram no ponto central do acoplamento e não são paralelas.

Los acoplamientos flexibles deben cumplir tres funciones básicas:

1. Acoplar físicamente dos ejes rotantes, transmitiendo el par de un eje a otro, directamente y a velocidad constante.
2. Compensar todos los tipos de desalineación entre los ejes acoplados, sin producir tensiones o cargas no previstas en los equipos conectados, y sin pérdidas significativas de potencia.
3. Compensar los desplazamientos o movimientos axiales de los ejes, evitando que uno provoque un empuje excesivo sobre el otro y permitiendo que cada uno gire en su posición normal.

Los tres tipos de desalineación que deben absorber los acoplamientos flexibles son:

1. Desalineación paralela: los ejes conectados son paralelos, pero no están sobre la misma línea.
2. Desalineación angular: los ejes se cortan, es decir están en su mismo plano, pero no en la misma línea.
3. Desalineación combinada angular-paralela: los ejes no se intersectan y no son paralelos

A flexible coupling must provide three basic functions:

1. Physically couple together two rotating shafts for efficient transmission of mechanical power, transferring the torque of one shaft to the other, directly and with constant velocity.
2. Compensate for all types of misalignment between rotating, connected shafts without inducing abnormal stresses and loads on connected equipment, and without tangible loss of power.
3. Compensate for end or axial movement of the coupled shafts, preventing either shaft from exerting excessive thrust on the other and allowing each to rotate in its normal position.

Three types of misalignment must be effectively accommodated by a flexible coupling.

1. Parallel Offset—axes of connected shafts are parallel, but not in the same straight line.
2. Angular—axes of shafts intersect at center point of coupling, but not in the same straight line.
3. Combined Angular-Offset—axes of shafts do not intersect at point of coupling and are not parallel.

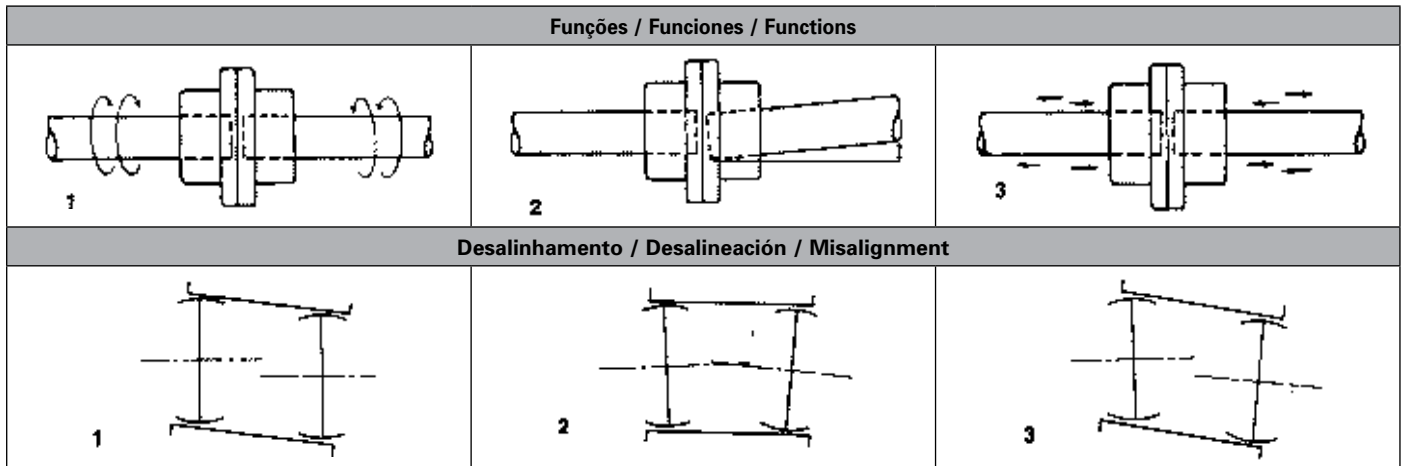

FS • Fatores de serviço recomendado / Factores de servicio recomendados / Recommended service factors

	Cargas / Load	Aplicação / Aplicación / Driven equipment	Tipo de acionamento / Tipo de accionamiento / Type driver		
			Motor turbine	Hidráulico Hydraulic	Motor alternativo Reciprocating engine
	Uniformes / Uniform	Bombas centrífugas•Transportador para cargas constantes• Ventiladores y sopladores•Generadores•Agitadores de líquidos•Misturadores/Centrifugal pumps • Exciters • Mixers-Liquid	1.0	1.25	1.50
	Cargas livianas / Light shock / Cargas leves	Bombas centrífugas•Generadores•Máquinas para madera•Bombas hidráulicas•Bombas oscilantes•Máquinas textiles/Centrifugal pumps•Generators-Pulsating load•Grinders • Hydraulic pumps • Kilns • Line shafting • Machine tools	1.5	1.75	2.00
	Cargas medias / Medium shock	Compresores•Multicilindros•Molinos•Elevadores•Accionamientos marinos•Grúas/Air compressors • Multi-cylinder • Ball and rod mills • Cranes • Elevators • Hoists • Punch presses	2.0	2.25	2.50
	Cargas pesadas / Heavy shock	Compresores de aire•Dragas•Máquinas de minería•Cilindros de acería•Misturadores de borracha/Drilling rigs • Mine machinery	2.5	2.75	3.00
	Cargas extremas / Extreme shock	Transportes vibratorios•Triturador/Ore crushers • Barstock shears • Vibrating conveyors	3.0	3.50	4.00



ACOPLAMENTOS DE ENGRENAGENS **POR** Informação técnica
ACOPLAMIENTOS DE ENGRANAJES **ESP** Información técnica
GEAR COUPLINGS **ENG** Technical data

Equivalências e intercambiabilidade / Guía de equivalencias e intercambiabilidade / Interchange guide

Tecnon serie 100	Tecnon	Falk Stell mill	Sier bath F	Kop Flex H Koppers	Kop Flex Fast	Kop Flex Waldron	Amerigear F Zurn	Falk Serie 1000	Flender Zin	Renold Ajax	Renold
101	1	1 GF	F-1	1 H	1	1	F 201	1010	Z 1	--	--
101¼	1¼	--	--	--	B 1½	--	--	--	--	--	--
101½	1½	1½ GF	F-1½	1½ H	1½	1½	F 201½	1015	Z 1½	1½	1½
102	2	2 GF	F-2	2 H	2	2	F 202	1020	Z 2	2	2
102½	2½	2½ GF	F-2½	2½ H	2½	2½	F 202½	1025	Z 2½	2½	2½
103	3	3 GF	F-3	3 H	3	3	F 203	1030	Z 3	3	3
103½	3½	3½ GF	F-3½	3½ H	3½	3½	F 203½	1035	Z 3½	3½	3½
104	4	4 GF	F-4	4 H	4	4	F 204	1040	Z 4	4	4
104½	4½	4½ GF	F-4½	4½ H	4½	4½	F 204½	1045	Z 4½	4½	4½
105	5	5 GF	F-5	5 H	5	5	F 205	1050	Z 5	5	5
105½	5½	5½ GF	F-5½	5½ H	5½	5½	F 205½	1055	Z 5½	5½	5½
106	6	6 GF	F-6	6 H	6	6	F 206	1060	Z 6	6	6
107	7	7 GF	F-7	7 H	7	7	F 207	1070	Z 7	7	7

Método de seleção

- 1• Compare os diâmetros do acionamento e da máquina aciodana com os furos máximos na tabela do catálogo
- 2• Seleccione o fator de serviço na tabela
- 3• Calcule o torque a ser transmitido. Nm= (9550 KW x FS)/rpm
- 4• Verifique a máxima velocidade da aplicação
- 5• Verifique as limitações de espaço

Método de selección

- 1• Comparar los Ø de los ejes conductor y conducido con el máximo alesaje según tabla del catálogo.
- 2• Verificar FS (*Factor de servicio*).
- 3• Verificar torque a transmitir. Nm= (9550 KW x FS)/rpm
- 4• Verificar las rpm máximas.
- 5• Verificar limitación de espacio.

Selection method

- 1• Compare shaft sizes of driving and driven equipment with listed maximum bores
- 2• Select a service factor from adjacent table
- 3• Compute torque to be transmitted. Torque (lb-in): (HP x 63,000 x SF)/rpm
{1 lb-in= 0.1129 Nm}
- 4• Check max speed of application
- 5• Check Space Limitations

Capacidade de desalinamento/ Capacidad de desalineación / Misalignment capacity

Tamanho tamanho size	instalação / instalación / installation (mm)		operação / operación / operation (mm)	
	Angular (A-B)	Paralelo P	Angular (A-B)	Paralelo P
101	0.12	0.087	1.52	0.522
101¼	0.14	0.111	1.67	0.660
101	0.17	0.131	2.06	0.860
102	0.22	0.168	2.61	1.000
102½	0.26	0.222	3.19	1.330
103	0.30	0.261	3.66	1.370
103½	0.35	0.315	4.24	1.890
104	0.42	0.356	5.02	2.136
104½	0.47	0.410	5.60	2.460
105	0.52	0.478	6.25	2.870
105½	0.60	0.520	7.30	3.120
106	0.64	0.545	7.72	3.270
107	0.77	0.652	9.32	3.910

São projetados para acomodar um desalinamento estático de 1/2" por lado. A instalação recomendada de desalinamento está limitado a 1/8" por lado

Están diseñados para acomodar un desalineamiento estático en 1/2" por lado. La recomendación para instalación es limitar el desalineamiento a 1/8" por lado del acoplamiento.

They are designed to accommodate a static misalignment of 1/2" per gear mesh. The recommended installation misalignment is limited to 1/8" per gear mesh.

**Duplo engrenamento
Doble compensador
Double engagement**

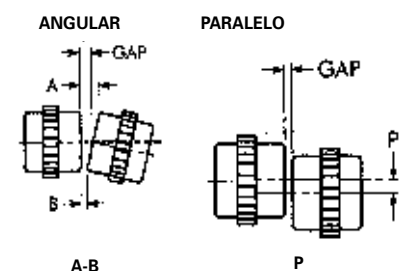

ACOPLAMENTOS DE ENGENAGENS **POR** Informação técnica
ACOPLAMIENTOS DE ENGRANAJES **ESP** Información técnica
GEAR COUPLINGS **ENG** Technical data

Recomendações da terminação da chaveta / Recomendaciones de terminado de chavetero / Recommend keyway furnished

Tamanho tamanho size	ØD	A (SAE)
101	-	-
101 1/4	55.5	1/4"
101 1/2	69.5	3/8"
102	86.5	
102 1/2	107.0	1/2"
103	122.0	
103 1/2	144.0	
104	170.0	3/4"
104 1/2	192.0	
105	210.0	
105 1/2	235.0	
106	262.0	1"
107	306.0	

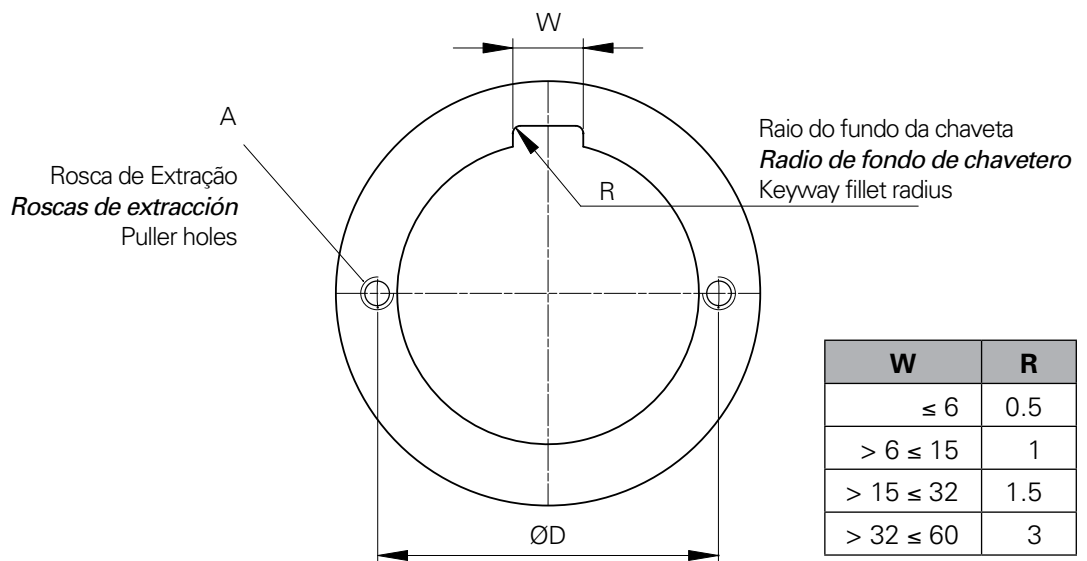

W	R
≤ 6	0.5
> 6 ≤ 15	1
> 15 ≤ 32	1.5
> 32 ≤ 60	3

Nota	Os furos maiores (d) deste catálogo são para chaveta retangular
Nota	Los agujeros máximos (d) de catálogo son para chavetas rectangulares
Note	The bigger holes (d) from this catalog are for rectangular key way

Tabela de tolerância de furos / Tabla de tolerancia de agujeros / Holes tolerance chart

Faixa dimensional Rango de dimensiones / size group (mm)	Eixo / Eje / Shaft m6		Tolerância de furo / Tolerancia agujeros / bore tolerance						
			Com folga/Con juego/Clearance fit		Justo/Incierto/Transition fit		Forçado/Forzado/Shrink fit		
	Tolerância/tolerancia/tolerance	F7	H7						
6 ≤ 10	+0,015	+0,006	+0,028	+0,013	+0,015	0	M7	0	-0,015
> 10 ≤ 18	+0,018	+0,007	+0,034	+0,016	+0,018	0		0	-0,018
> 18 ≤ 30	+0,021	+0,008	+0,041	+0,020	+0,021	0		0	-0,021
> 30 ≤ 50	+0,025	+0,009	+0,050	+0,025	+0,025	0		0	-0,025
> 50 ≤ 80	+0,030	+0,011	+0,060	+0,030	+0,030	0		0	-0,030
> 80 ≤ 120	+0,035	+0,013	+0,071	+0,036	+0,035	0		0	-0,035
> 120 ≤ 180	+0,040	+0,015	+0,083	+0,043	+0,040	0	N7	-0,012	-0,052
> 180 ≤ 250	+0,046	+0,017	+0,096	+0,050	+0,046	0		-0,014	-0,060
> 250 ≤ 315	+0,052	+0,020	+0,108	+0,056	+0,052	0		-0,014	-0,066
> 315 ≤ 400	+0,057	+0,021	+0,119	+0,062	+0,057	0		-0,016	-0,073
> 400 ≤ 500	+0,063	+0,023	+0,131	+0,068	+0,063	0		-0,017	-0,080

Classe de montagem recomendado para os acoples Tecnon: Forçado
 Tipo de montaje recomendado para los acoples Tecnon: Forzado
 Recommended assembly type for Tecnoncouplings: Shrink

Los diagramas, figuras e imágenes contenidas en este catálogo son estrictamente a modo ilustrativo.
 Tecnon se reserva el derecho de modificar cualquier dato o especificación sin previo aviso.
 The contents of this bulletin are subject without notice or obligation.
 Information contained herein should be confirmed before placing orders.



ACOPLAMENTOS DE ENGRENAGENS **POR** Dimensões dos flanges

ACOPLAMIENTOS DE ENGRANAJES **ESP** Detalle de las bridas de las campanas

GEAR COUPLINGS **ENG** Flanged sleeve and rigid hub details

Conforme Norma AGMA 516-01
Cumple Norma AGMA 516-01
Meets AGMA 516-01

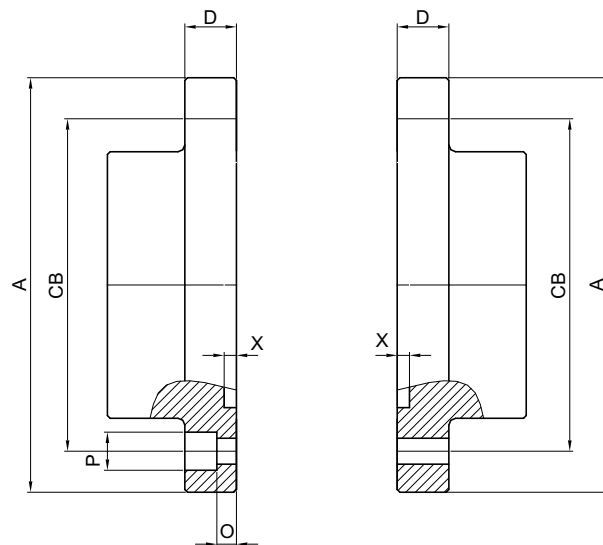

Embutido / Shrouded

Expostos / Expostos / Exposed

Tamaño Tamaño Size	Dimensões comuns parafusos expostos e embutidos / Dimensiones comunes bulones expuestos y embutidos / Shrouded or exposed bolts			Parafusos expostos / Bulones expuestos / Exposed bolts			Parafusos embutidos / Bulones embutidos / Shrouded bolts				
	A	D	X	CB	Nº	Size	CB	Nº	Size	P	O
101	115.88	14.0	1.5	95.25	6	1/4" x 1 1/2	95.25	6	1/4" x 3/4"	16	5
101 1/4	130.00	16.0	1.5	104.00	6	5/16" x 1 3/4	104.00	6	5/16" x 7/8"	20	6
101 1/2	152.40	19.0	2.0	122.23	8	3/8" x 2	122.23	8	3/8" x 1"	22	6
102	177.80	19.0	2.0	149.20	6	1/2" x 2 1/4	147.60	10	3/8" x 1"	22	6
102 1/2	212.70	22.0	3.0	181.00	6	5/8" x 2 1/2	177.80	10	1/2" x 1 1/4"	26	7
103	239.70	22.0	3.0	206.40	8	5/8" x 2 1/2	203.23	12	1/2" x 1 1/4"	26	7
103 1/2	279.40	27.0	3.0	241.30	8	3/4" x 3	235.70	12	5/8" x 1 1/2"	34	9
104	317.50	27.0	3.0	279.40	8	3/4" x 3	269.90	14	5/8" x 1 1/2"	34	9
104 1/2	346.10	27.0	4.0	304.80	10	3/4" x 3	298.50	14	5/8" x 1 1/2"	34	9
105	388.90	38.0	4.0	342.90	8	7/8" x 4	335.00	14	3/4" x 2"	40	13
105 1/2	425.45	38.0	5.0	368.30	14	7/8" x 4	366.72	16	3/4" x 2"	40	16
106	457.20	25.0	4.0	400.00	14	7/8" x 4					
107	527.00	28.5	8.0	463.55	16	1" x 4					
8	590.60	33.0		527.00	16						
9	660.40	36.0		590.60	18						
10	711.00	38.0		641.30	18						
11	774.70	41.0		698.50	18						
12	838.00	41.0		762.00	18						

ACOPLAMENTOS DE ENGRENAGENS **POR** Duplo Engrenamento
ACOPLAMIENTOS DE ENGRANAJES **ESP** Doble compensador
GEAR COUPLINGS **ENG** Double engagement

TADF/B

TADF/A

Vedação por câmara redentora
 Cierre laberíntico
 Labyrinth Seal

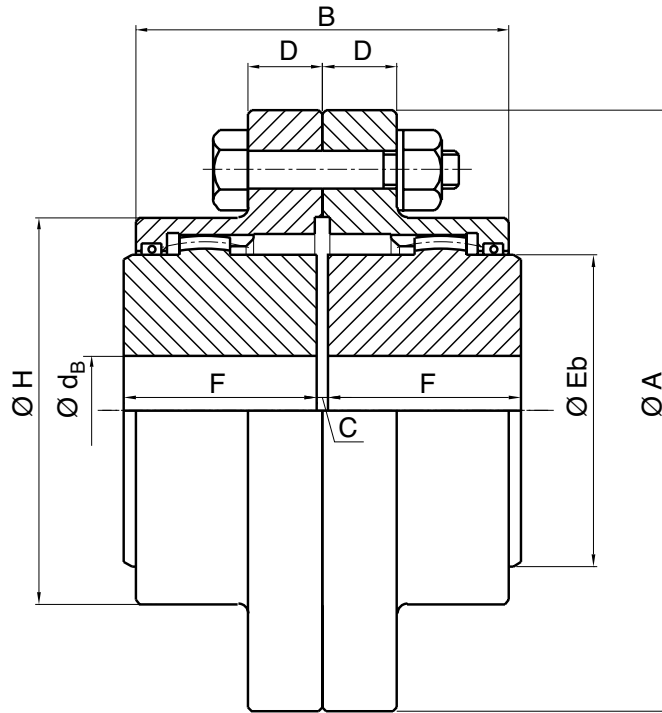
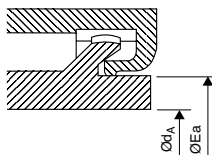

Fabricados em:

- Aço SAE 1045 tratados termicamente a uma dureza de 240-260 Brinell.
- Aço SAE 4140 beneficiados e nitretados a uma dureza de 45-50 Rc.

Fabricados en:

- Acero SAE 1045 tratados termicamente a uma dureza de 240-260 Brinell.
- Acero SAE 4140 bonificados y nitruados a 45-50 Rc.

Manufactured in:

- SAE 1045 steel, heat treated with a hardness Brinell 240-260.
- SAE 4140 steel, boron treated and nitrided to 45-50 Rc.

Parafusos Bulones Bolts

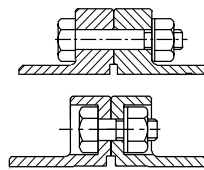

Os acoplamentos Tecnon podem ser fornecidos com parafusos expostos ou embutidos.

Los acoplamientos Tecnon pueden ser suministrados con bulones expuestos o bulones embutidos.

Couplings may be furnished with exposed bolts or shrouded bolts.

Tamaño Tamaño Size	Torque Nm	HP/ 100 rpm	rpm max	ø dB max	ø dA max	A	B	D	F	H	Eb	Ea	C gap	Peso Weight Kg
101	1140	16	8000	44	37	115.9	72.0	14.0	41	76.0	58	48	3.0	3.7
101 ¹ / ₄	1756	25	7250	47	43	130.0	83.0	16.0	43	83.0	64	55	3.0	5.2
101 ¹ / ₂	2348	34	6500	60	54	152.4	95.0	19.0	49	98.0	79	69	3.0	8.5
102	4269	61	5600	73	71	177.8	120.0	19.0	62	124.5	100	92	3.0	13.3
102 ¹ / ₂	7470	107	5000	92	84	212.8	148.0	22.0	77	149.0	122	109	5.0	25.0
103	12094	172	4400	105	95	239.7	178.0	22.0	91	174.0	140	123	5.0	37.0
103 ¹ / ₂	18496	264	3900	123	105	279.4	206.0	27.0	106	200.0	162	140	6.0	59.0
104	30590	436	3600	146	120	317.5	234.0	27.0	120	234.0	192	168	6.0	86.0
104 ¹ / ₂	41971	598	3200	171	135	346.1	262.0	27.0	135	263.0	214	182	8.0	121.0
105	56560	806	2900	183	160	388.9	298.0	38.0	153	293.0	239	210	8.0	171.0
105 ¹ / ₂	73985	1054	2650	205	175	425.5	316.0	38.0	168	325.0	267	235	8.0	239.0
106	90345	1287	2450	230	190	457.2	338.0	25.0	188	356.0	295	250	8.0	267.0
107	135160	1926	2150	270	----	527.0	396.0	28.5	221	406.0	342	----	10.0	465.0



ACOPLAMENTOS DE ENGRENAGENS **POR** **Duplo Engrenamento. Cubos invertidos**
ACOPLAMIENTOS DE ENGRANAJES **ESP** **Doble compensador. Cubos invertidos**
GEAR COUPLINGS **ENG** **Double engagement. Hubs reversed**

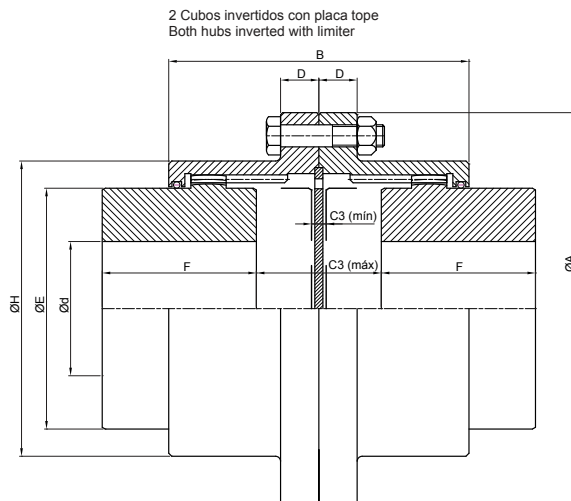
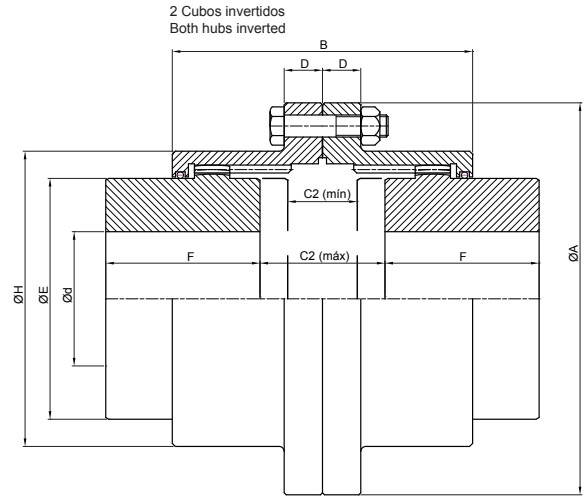
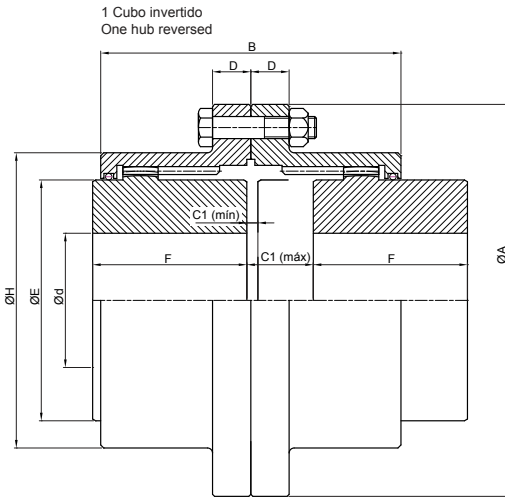

TADF/BCI

Fabricados em:

- Aço SAE 1045 tratados termicamente a uma dureza de 240-260 Brinell.
- Aço SAE 4140 beneficiados e nitretados a uma dureza de 45-50 Rc.

Fabricados en:

- Acero SAE 1045 tratados termicamente a uma dureza de 240-260 Brinell.
- Acero SAE 4140 bonificados y nitruados a 45-50 Rc.

Manufactured in:

- SAE 1045 steel, heat treated with a hardness Brinell 240-260.
- SAE 4140 steel, boron treated and nitrided to 45-50 Rc.

**Parafusos
Bulones
Bolts**

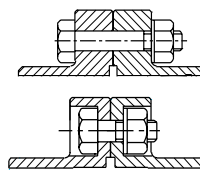

Os acoplamentos Tecnon podem ser fornecidos com parafusos expostos ou embutidos.

Los acoplamientos Tecnon pueden ser suministrados con bulones expuestos o bulones embutidos.

Couplings may be furnished with exposed bolts or shrouded bolts.

Tamanho Tamaño Size	Torque Nm	HP 100 rpm	rpm máx	Ød máx	A	B	D	F	H	E	C1		C2		C3		Peso Kg
											mín	máx	mín	máx	mín	máx	
101 1/4	1756	25	7250	47	130.0	83	16.0	43	83	64	5.0	8.0	10.0	13	6	13	5.2
101 1/2	2348	34	6500	60	152.4	95	19.0	49	98	79	6.0	11.0	13.5	19	8	19	8.5
102	4269	61	5600	73	177.8	120	19.0	62	125	100	5.0	15.0	16.5	27	8	27	13.3
102 1/2	7470	107	5000	92	212.7	148	22.0	77	149	122	5.0	25.0	25.0	45	10	45	25.0
103	12094	172	4400	105	239.7	178	22.0	91	174	140	5.0	28.5	27.0	52	10	52	37.0
103 1/2	18496	264	3900	123	279.4	206	27.0	106	200	162	8.5	38.5	41.0	71	11	71	59.0
104	30590	436	3600	146	317.5	234	27.0	120	234	192	9.0	43.0	46.0	80	16	80	86.0
104 1/2	41971	598	3200	171	346.1	262	27.0	135	263	214	11.0	53.0	56.0	98	18	98	121.0
105	56560	806	2900	183	388.9	298	38.0	153	293	239	11.0	66.0	69.0	124	18	124	171.0
105 1/2	73985	1054	2650	205	425.5	314	38.0	168	325	267	8.0	64.0	64.0	120	18	120	239.0
106	90345	1287	2450	230	457.2	336	25.0	188	356	295	12.0	62.0	66.0	116	21	116	267.0
107	135160	1926	2150	270	527.0	396	28.5	221	406	342	14.5	84.5	89.0	159	25	159	465.0

Gap de montagem: valores entre Cmin e Cmax / Gap de montaje: valores entre Cmin y Cmax / Montage Gap: values from Cmin -Cmax



ACOPLAMENTOS DE ENGENAGENS **POR** Duplo Engrenamento
ACOPLAMIENTOS DE ENGRANAJES **ESP** Doble compensador
GEAR COUPLINGS **ENG** Double engagement

TADF/BF

TADF/AF
 Vedação por câmara redentora
 Cierre laberíntico
 Labyrinth Seal

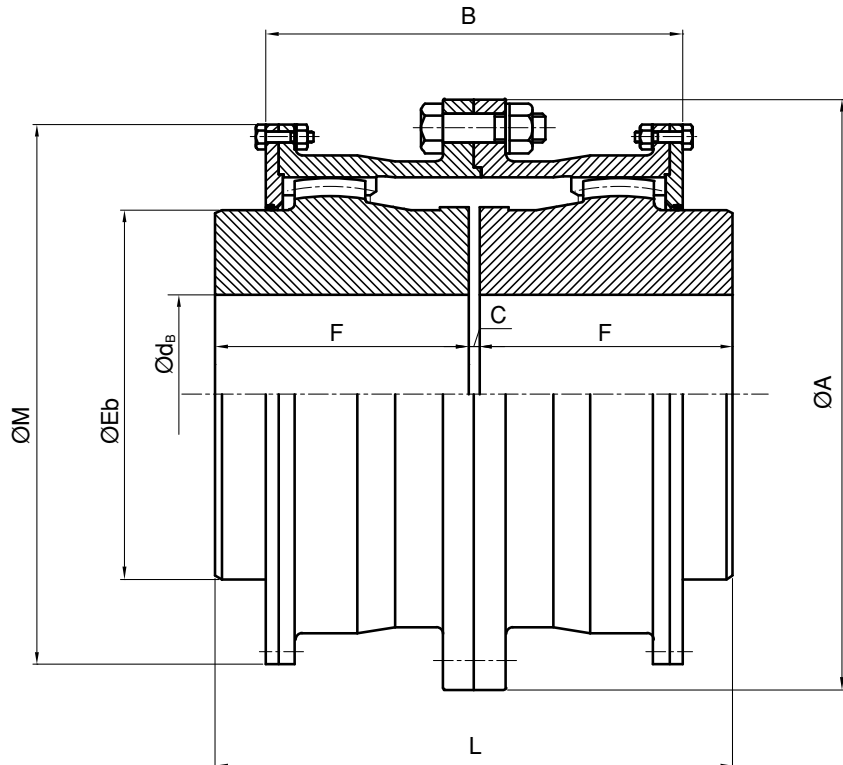
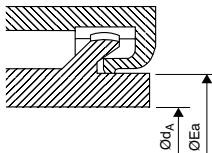

Série aço fundido
SERIE ACERO FUNDIDO
Cast Steel Series

Tamanho Tamaño Size	Torque Nm	HP/ 100 rpm	rpm max	ø dB max	ø dA max	A	B	M	Eb	Ea	L	F	C gap
8	287370	4094	1700	270	214	590.6	410	540	355	300	508	249	10
9	390000	5556	1550	300	243	660.4	457	600	394	340	565	276	13
10	547370	7798	1400	340	303	711.0	501	650	445	425	623	305	13
11	752630	10723	1300	380	330	774.7	553	716	495	465	679	333	13
12	957895	13648	1200	420	336	838.0	604	776	546	480	717	352	13



ACOPLAMENTOS DE ENGENAGENS **POR** Compacto
ACOPLAMIENTOS DE ENGRANAJES **ESP** Compacto
GEAR COUPLINGS **ENG** Continuos sleeve

TADF/BC

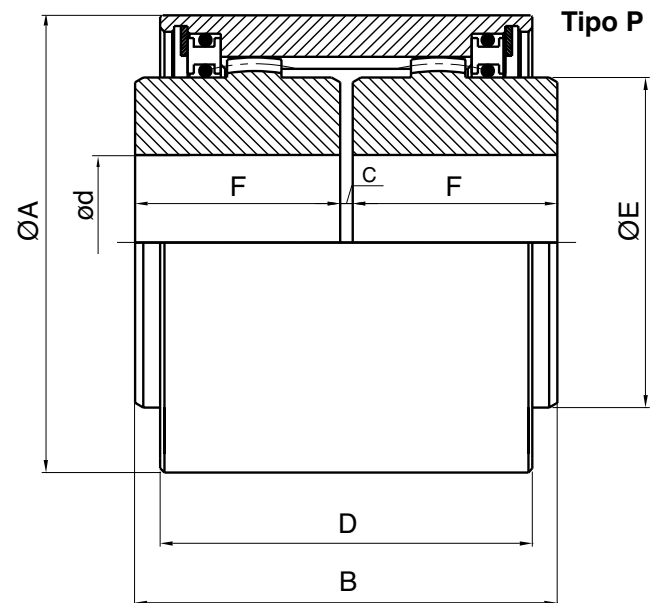
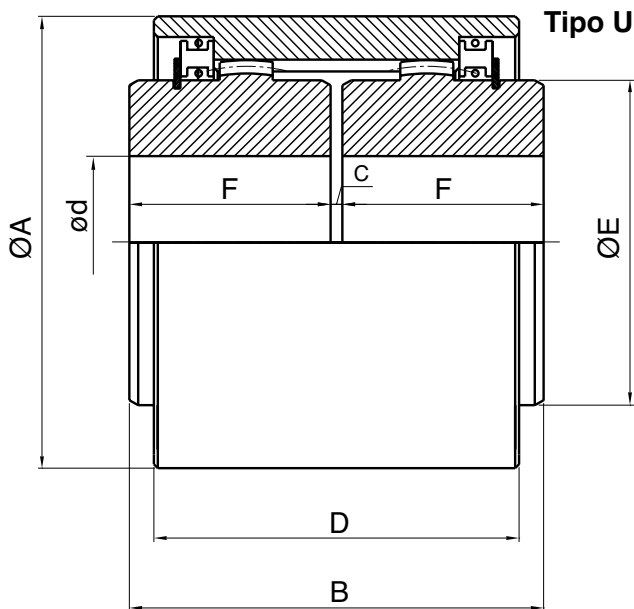

Fabricados em:

- Aço SAE 1045 tratados termicamente a uma dureza de 240-260 Brinell.
- Aço SAE 4140 beneficiados e nitretados a uma dureza de 45-50 Rc.

Fabricados en:

- Acero SAE 1045 tratados termicamente a uma dureza de 240-260 Brinell.
- Acero SAE 4140 bonificados y nitruados a 45-50 Rc.

Manufactured in:

- SAE 1045 steel, heat treated with a hardness Brinell 240-260.
- SAE 4140 steel, boron treated and nitrided to 45-50 Rc.

Tamaño Tamaño Size	Torque Nm	HP/ 100 rpm	rpm max	ø d max	A	B	F	E	D	C gap	Peso Weight Kg
101	1140	16	8900	44	86	85	41	58	79	3	1.8
101½	2348	34	7700	60	110	101	49	79	89	3	6.5
102	4269	61	6700	73	138	127	62	100	108	3	12.6
102½	7470	107	6000	92	158	159	77	122	123	5	20.0
103	12094	172	5200	105	185	187	91	140	142	5	30.0
103½	18496	264	4800	123	210	218	106	162	153	6	47.0
104	30590	436	4300	146	250	246	120	192	182	6	68.0

ACOPLAMENTOS DE ENGRENAGENS **POR** Simple engrenamento
ACOPLAMIENTOS DE ENGRANAJES **ESP** Simple compensador
GEAR COUPLINGS **ENG** Single engagement

TADSF/B

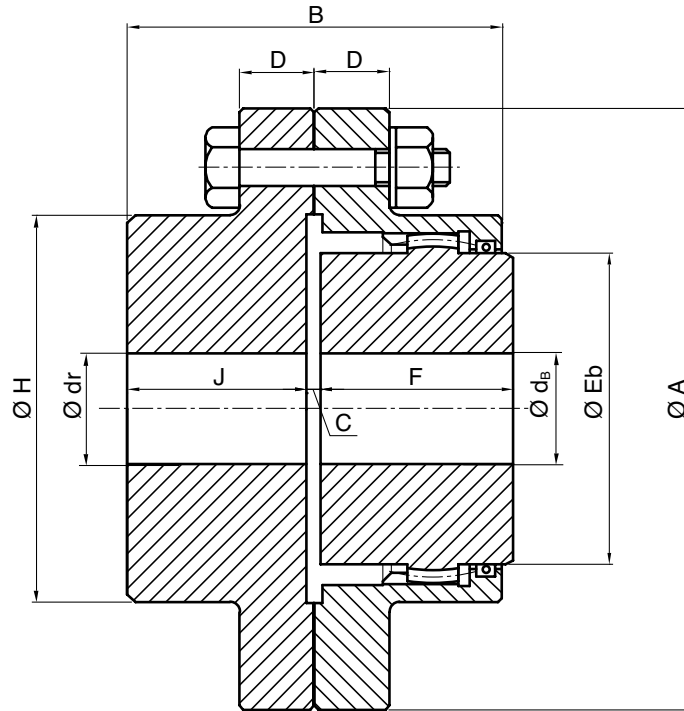

TADSF/A

Vedação por câmara redentora
 Cierre laberíntico
 Labyrinth Seal

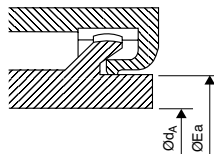

Fabricados em:

- Aço SAE 1045 tratados termicamente a uma dureza de 240-260 Brinell.
- Aço SAE 4140 beneficiados e nitretados a uma dureza de 45-50 Rc.

Fabricados en:

- Acero SAE 1045 tratados termicamente a uma dureza de 240-260 Brinell.
- Acero SAE 4140 bonificados y nitruados a 45-50 Rc.

Manufactured in:

- SAE 1045 steel, heat treated with a hardness Brinell 240-260.
- SAE 4140 steel, boron treated and nitrided to 45-50 Rc.

Parafusos Bulones Bolts

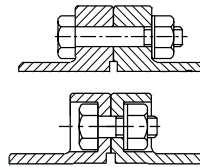

Os acoplamentos Tecnon podem ser fornecidos com parafusos expostos ou embutidos.

Los acoplamientos Tecnon pueden ser suministrados con bulones expuestos o bulones embutidos.

Couplings may be furnished with exposed bolts or shrouded bolts.

Tamanho Tamaño Size	Torque Nm	HP/ 100 rpm	rpm max	ø dB max	ø dA max	ø dr max	A	B	D	F	J	H	Eb	Ea	C min	C* max	Peso Weight Kg
101	1140	16	8000	44	37	55	115.9	72.0	14.0	41	34.5	76.0	58	48	3.0	3.0	4.2
101¼	1756	25	7250	47	43	61	130.0	83.0	16.0	43	40.0	83.0	64	55	3.0	8.0	5.2
101½	2348	34	6500	60	54	74	152.4	95.0	19.0	49	45.5	98.0	79	69	3.5	11.5	8.8
102	4269	61	5600	73	71	91	177.8	120.0	19.0	62	58.0	124.5	100	92	3.5	15.5	14.4
102½	7470	107	5000	92	84	112	212.8	148.0	22.0	77	71.0	149.0	122	109	5.5	25.5	25.5
103	12094	172	4400	105	95	131	239.7	178.0	22.0	91	86.0	174.0	140	123	5.5	29.0	39.5
103½	18496	264	3900	123	105	151	279.4	206.0	27.0	106	100.0	200.0	162	140	6.0	38.5	61.0
104	30590	436	3600	146	120	177	317.5	234.0	27.0	120	114.0	234.0	192	168	6.0	43.0	91.0
104½	41971	598	3200	171	135	207	346.1	262.0	27.0	135	127.0	263.0	214	182	8.0	53.0	123.0
105	56560	806	2900	183	160	224	388.9	298.0	38.0	153	145.0	293.0	239	210	8.0	66.0	182.0
105½	73985	1054	2650	205	175	250	425.5	316.0	38.0	168	153.0	325.0	267	235	9.0	64.0	260.0
106	90345	1287	2450	230	190	278	457.2	338.0	25.0	188	164.0	356.0	295	250	8.0	62.0	320.0
107	135160	1926	2150	270	---	320	527.0	396.0	28.5	221	187.5	406.0	342	---	13.0	84.5	502.0

Gap de montagem: valores entre Cmin e Cmax / Gap de montaje: valores entre Cmin y C max / Montage Gap: values from Cmin -Cmax
 *Cmax: Cubo invertido/Hub inverted



ACOPLAMENTOS DE ENGENAGENS **POR** Simple engrenamento
 ACOPLAMIENTOS DE ENGRANAJES **ESP** Simple compensador
 GEAR COUPLINGS **ENG** Single engagement

TADSF/BF

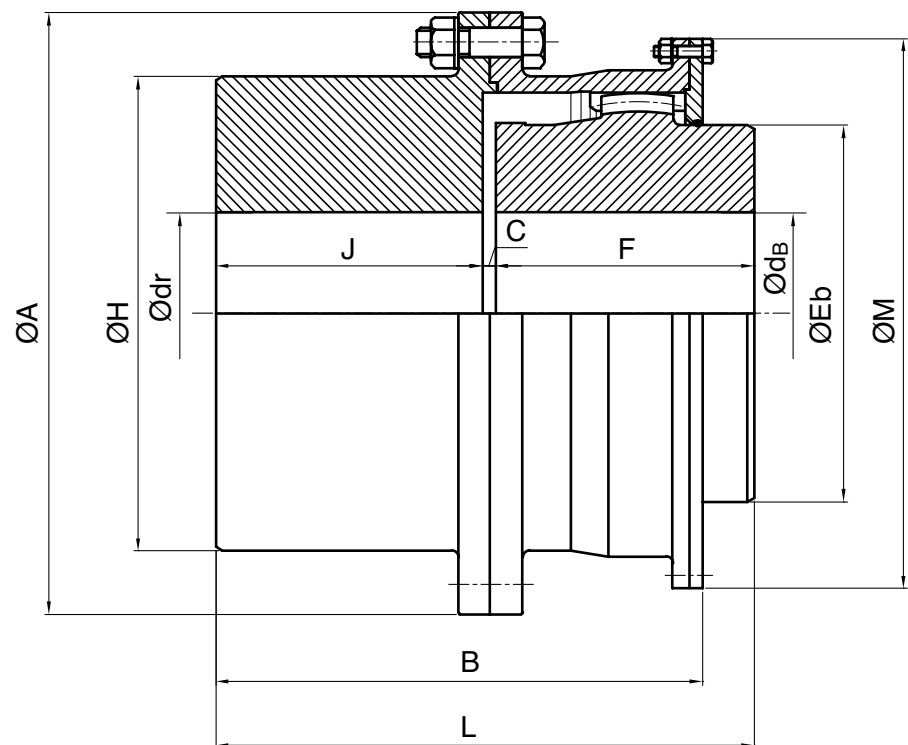

TADSF/AF

Vedação por câmara redentora
 Cierre laberíntico
 Labyrinth Seal

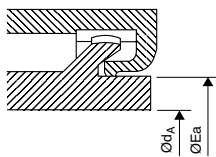

Série aço fundido SERIE ACERO FUNDIDO Cast Steel Series

Tamanho Tamaño Size	Torque Nm	HP/ 100 rpm	rpm max	ø dB max	ø dA max	ø dr max	A	B	M	Eb	Ea	L	F	J	H	C gap
8	287370	4094	1700	253	214	322	590.6	459	540	355	300	508	249	249	462	10
9	390000	5556	1550	281	243	363	660.4	511	600	394	340	565	276	276	516	13
10	547370	7798	1400	318	303	378	711.0	562	650	455	425	623	305	305	561	13
11	752630	10723	1300	353	330	417	774.7	616	716	495	465	679	333	333	618	13
12	957895	13648	1200	378	336	463	838.0	652	776	530	470	717	352	352	680	13

ACOPLAMENTOS DE ENGRENAGENS **POR** Mill motor / Eixo cônico
ACOPLAMIENTOS DE ENGRANAJES **ESP** Para eje cónico
GEAR COUPLINGS **ENG** Mill motor couplings

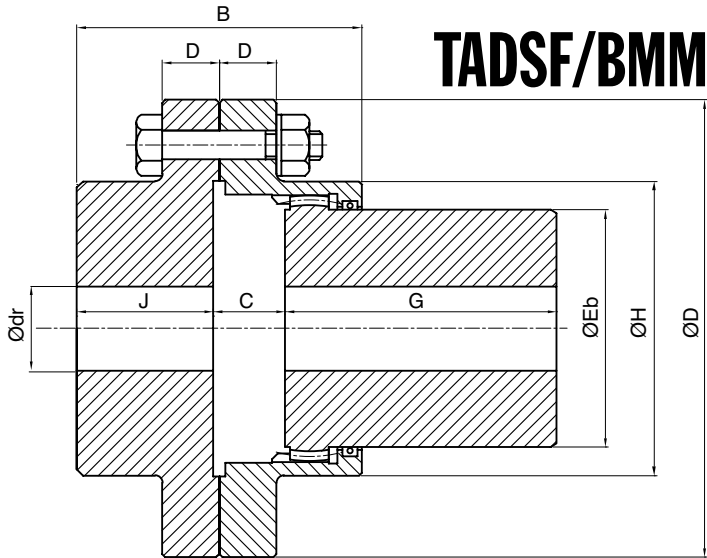

TADF/AMM

Vedação por câmara redentora
 Cierre laberíntico
 Labyrinth Seal

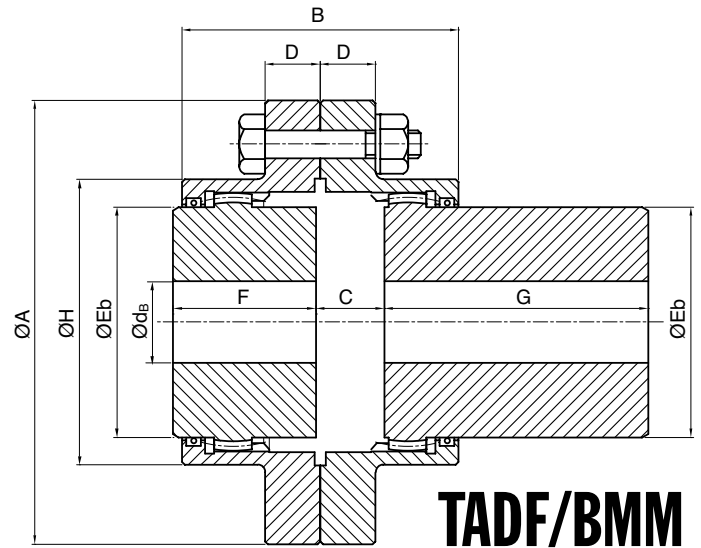
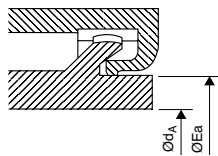

Fabricados em:

- Aço SAE 1045 tratados termicamente a uma dureza de 240-260 Brinell.
- Aço SAE 4140 beneficiados e nitretados a uma dureza de 45-50 Rc.

Fabricados en:

- Acero SAE 1045 tratados termicamente a una dureza de 240-260 Brinell.
- Acero SAE 4140 bonificados y nitruados a 45-50 Rc.

Manufactured in:

- SAE 1045 steel, heat treated with a hardness Brinell 240-260.
- SAE 4140 steel, boron treated and nitrided to 45-50 Rc.

**Parafusos
 Bulones
 Bolts**

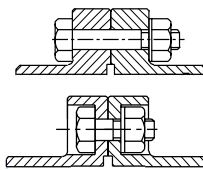

Os acoplamentos Tecnon podem ser fornecidos com parafusos expostos ou embutidos.

Los acoplamientos Tecnon pueden ser suministrados con bulones expuestos o bulones embutidos.

Couplings may be furnished with exposed bolts or shrouded bolts.

Tamanho Tamaño Size	Torque Nm	HP/ 100 rpm	rpm max	ø dB max	ø dA max	ø dr max	A	B	D	F	H	G	J	Eb	Ea	C*	Peso Weight Kg
101½	2380	34	6500	60	54	74	152.4	95	19	49	98.0	93	45.5	79	69	Determinado pelo eixo cônico Determinado por el eje cónico Determined by shaft mill motor	9.7
102	4269	61	5600	73	71	91	177.8	120	19	62	124.5	106	58.0	100	92		16.5
102½	7470	107	5000	92	84	112	212.8	148	22	77	149.0	139	71.0	122	109		28.5
103	12094	172	4400	105	95	131	239.7	178	22	91	174.0	137	86.0	140	123		41.0
103½	18496	264	3900	123	105	151	279.4	206	27	106	200.0	156	100.0	162	140		60.0
104	30590	436	3600	146	120	177	317.5	234	27	120	234.0	152	114.0	192	168		97.0
104½	41971	598	3200	171	135	207	346.1	262	27	135	263.0	183	127.0	214	182		122.0
105	56560	806	2900	183	160	224	388.9	298	38	153	293.0	262	145.0	239	210		206.0
105½	73985	1054	2650	205	175	250	425.5	316	38	168	325.0	262	153.0	267	235		239.0
106	90345	1287	2450	230	190	278	457.0	342	25	188	356.0	262	164	295	250		265.0

* Veja medidas/ver dimensiones/see measurements Mill Motor



ACOPLAMENTOS DE ENGRANAGENS **POR** **Mill Motor Eixo cônico Normas AISE**
ACOPLAMIENTOS DE ENGRANAJES **ESP** **Para ejes cónico Normas AISE**
GEAR COUPLINGS **ENG** **Mill Motor hub for AISE shafts**

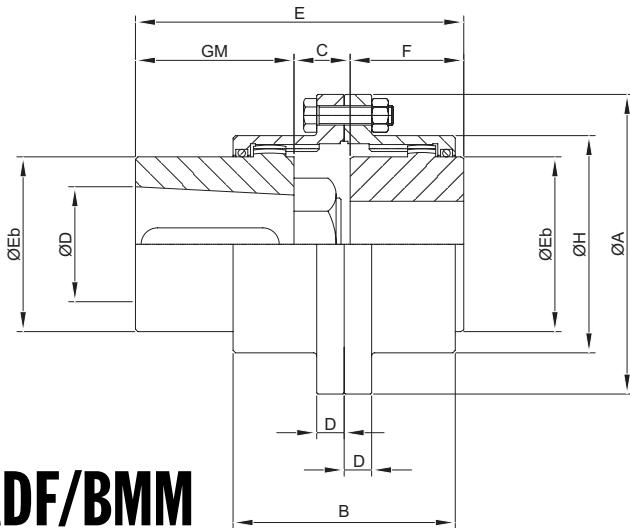

TADF/BMM

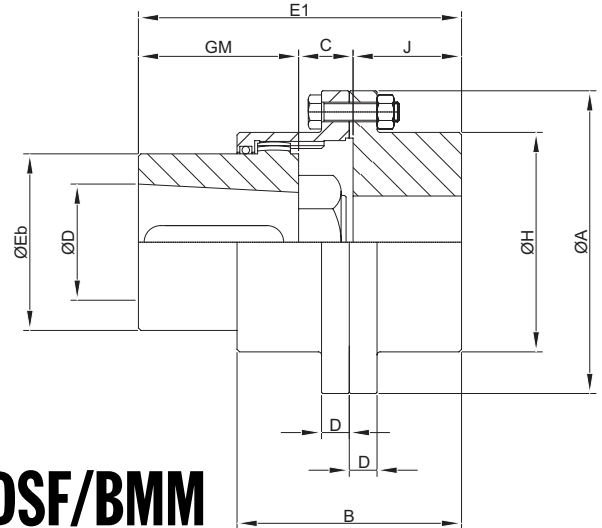

TDSF/BMM

Tamaño Tamaño Size	Motor AISE	Ø A	Ø Eb	Ø D	Ø H	Gm	B	C	D	TADF / BMM		TASF / BMM	
										E	F	E1	J
101 1/2	602	152.4	79.0	44.4	98.0	78.4	95.0	25.0	19.0	152.4	49.0	148.9	45.5
	603			50.8		92.6		25.0		166.6		163.1	
	604			50.8		92.6		25.0		166.6		163.1	
102	602	177.8	100.0	44.4	124.5	76.2	120.0	27.0	19.0	165.2	62.0	161.2	58.0
	603			50.8		89.0		28.5		179.5		175.5	
	604			50.8		89.0		28.5		179.5		175.5	
102 1/2	606	212.7	122.0	63.5	149.0	101.6	148.0	31.8	22.0	195.4	77.0	191.4	71.0
	603			50.8		89.0		30.2		196.2		190.2	
	604			50.8		89.0		30.2		196.2		190.2	
	606			63.5		101.6		33.3		211.9		205.9	
	608			82.5		114.3		36.6		227.9		221.9	
103	610	239.7	140.0	82.5	174.0	114.3	178.0	39.6	22.0	230.9	91.0	224.9	86.0
	612			92.1		127.0		42.4		246.4		240.4	
	606			63.5		101.6		33.3		225.9		220.9	
	608			76.2		114.3		36.6		241.9		236.9	
	610			82.5		114.3		39.6		244.9		239.9	
103 1/2	612	279.4	162.0	92.1	200.0	127.0	206.0	43.0	27.0	261.0	106.0	256.0	100.0
	614			107.9		127.0		47.8		280.8		274.8	
	616			117.5		139.7		51.0		296.7		290.7	
	606			63.5		101.6		35.0		242.6		236.6	
	608			76.2		114.3		38.1		258.4		252.4	
	610			82.5		114.3		41.1		261.4		255.4	
104	612	317.5	192.0	92.1	234.0	127.0	234.0	44.5	27.0	277.5	120.0	271.5	114.0
	614			107.9		127.0		47.8		294.8		288.8	
	616			117.5		139.7		51.0		310.7		304.7	
	618			127.0		152.4		51.0		310.7		304.7	
	610			82.5		114.3		41.0		275.3		269.3	
104 1/2	612	346.1	214.0	92.1	263.0	127.0	262.0	46.0	27.0	308.0	135.0	300.0	127.0
	614			107.9		127.0		49.3		311.3		303.3	
	616			117.5		139.7		52.3		327.0		319.0	
	618			127.0		152.4		52.3		328.5		320.5	
	620			149.2		171.5		52.3		358.8		350.8	
105	614	388.9	239.0	107.9	293.0	127.0	298.0	49.3	38.0	329.3	153.0	321.3	145.0
	616			117.5		139.7		52.3		345.0		337.0	
	618			127.0		152.4		52.3		346.5		338.5	
	620			149.2		171.5		52.3		376.8		368.8	
	622			158.7		184.2		68.3		405.5		397.5	
105 1/2	624	425.5	267.0	177.8	325.0	235.0	314.0	68.3	38.0	456.3	168.0	448.3	153.0
	618			127.0		152.4		41.1		361.5		346.5	
	620			149.2		171.5		52.3		391.8		376.8	
	622			158.8		184.2		68.3		420.5		405.5	
106	624	457.2	295.0	177.8	356.0	235.0	336.0	68.3	25.0	471.3	188.0	456.3	164.0
	616			117.5		139.7		52.3		380.0		356.0	
	618			127.0		152.4		41.1		381.5		357.5	
	620			149.2		171.5		52.3		411.8		387.8	
	622			158.7		184.2		68.3		440.5		416.5	



ACOPLAMENTOS DE ENGENAGENS **POR** **Cubos Mill Motor para eixo cônico Normas AISE**
ACOPLAMIENTOS DE ENGRANAJES **ESP** **Cubos Mill Motor para ejes cónico**
GEAR COUPLINGS **ENG** **Mill Motor hub for AISE shafts**

TADF/BMM

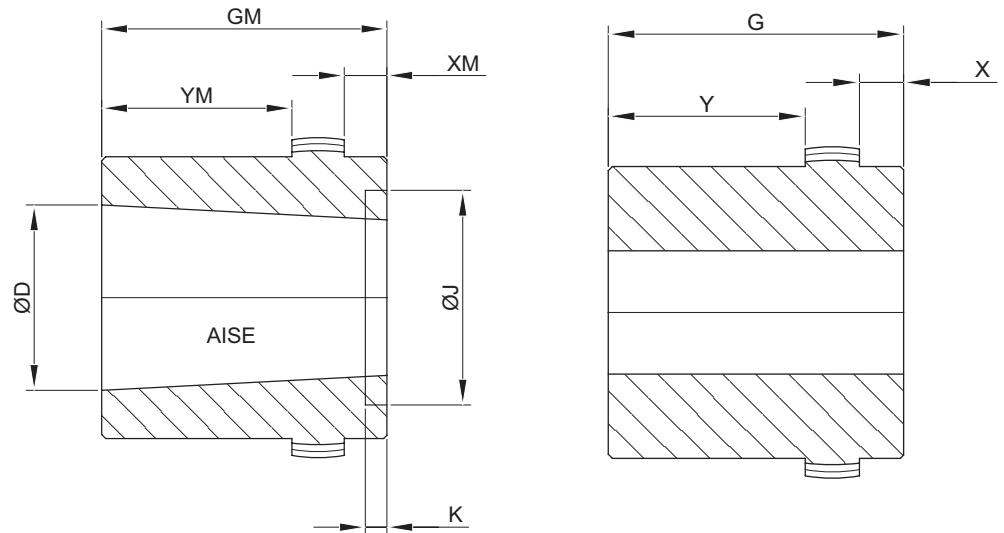

Conicidade: 11/4" x pés em \varnothing
 Conicidad: 11/4" x pie en \varnothing
 Bore taper: 11/4" x per ft. on \varnothing

Tamanho Tamaño Size	Motor AISE	Std AISE					Stock			
		Xm	Ym	Gm	ØD	ØJ	K	X	Y	G
101 1/2	602	-	62.4	78.4	44.4	71.5	2.2	-	76.6	92.6
	603	-	76.6	92.6	50.8		3.7	-		
	604	-	76.6	92.6	50.8		3.7	-		
102	602	4.5	51.2	76.2	44.4	-	-	4.5	81.1	106.1
	603	3.0	65.5	89.0	50.8					
	604	3.0	65.5	89.0	50.8					
	606	-	81.1	101.6	63.5					
102 1/2	603	13.3	52.2	89.0	50.8	-	-	13.3	102.2	139.0
	604	13.3	52.2	89.0	50.8					
	606	10.2	67.9	101.6	63.5					
	608	6.9	83.9	114.3	82.5					
	610	3.9	86.9	114.3	82.5					
103	612	1.3	102.2	127.0	92.1	-	-	18.2	92.5	136.7
	606	18.2	57.4	101.6	63.5					
	608	14.9	73.4	114.3	76.2					
	610	11.9	76.4	114.3	82.5					
103 1/2	612	8.5	92.5	127.0	92.1	-	-	27.5	98.7	155.7
	606	27.5	44.6	101.6	63.5					
	608	24.4	60.4	114.3	76.2					
	610	21.4	63.4	114.3	82.5					
	612	18.0	79.5	127.0	92.1					
	614	14.7	82.8	127.0	107.9					
104	616	11.5	98.7	139.7	117.5	-	-	30.4	88.0	152.4
	610	29.0	51.3	114.3	82.5					
	612	25.5	67.5	127.0	92.1					
	614	22.2	70.8	127.0	107.9					
	616	19.0	86.7	139.7	117.5					
	618	30.4	88.0	152.4	127.0					
104 1/2	612	36.0	54.0	127.0	92.1	-	-	40.9	104.8	182.7
	614	32.7	57.3	127.0	107.9					
	616	29.7	73.0	139.7	117.5					
	618	40.9	74.5	152.4	127.0					
	620	29.7	104.8	171.5	149.2					
105	614	46.7	39.3	127.0	107.9	-	-	54.9	166.3	262.2
	616	43.7	55.0	139.7	117.5					
	618	54.9	56.5	152.4	127.0					
	620	43.7	86.8	171.5	149.2					
	622	27.7	115.5	184.2	158.7					
	624	27.7	166.3	235.0	177.8					
105 1/2	618	60.0	48.4	152.4	127.0	-	-	60.0	158.3	262.3
	620	48.7	78.8	171.5	149.2					
	622	32.7	107.5	184.2	158.8					
	624	32.7	158.3	235.0	177.8					
106	616	55.7	36.0	139.7	117.5	-	-	66.9	147.3	262.2
	618	66.9	37.5	152.4	127.0					
	620	55.7	67.8	171.5	149.2					
	622	39.7	96.5	184.2	158.7					
	624	39.7	147.3	235.0	177.8					



ACOPLAMENTOS DE ENGRENAGENS **POR** Deslocamento axial

ACOPLAMIENTOS DE ENGRANAJES **ESP** Desplazamiento axial

GEAR COUPLINGS **ENG** Slide couplings

TADF/BGL1

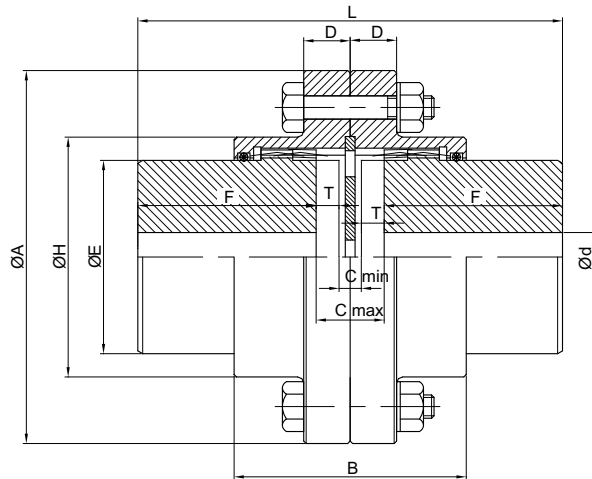

TADF/BGL2

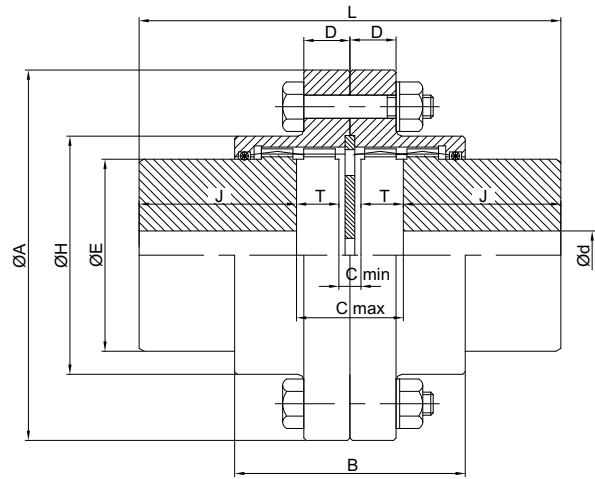

Tamaño Tamaño Size	Torque Nm	HP/ 100 rpm	rpm max	ø d max	A	B	D	F	H	E	J
101	1140	16	8000	44	115.9	72.0	14.0	41	76.0	58	---
101 ¹ / ₄	1756	25	7250	47	130.0	83.0	16.0	43	83.0	64	80.0
101 ¹ / ₂	2348	34	6500	60	152.4	95.0	19.0	49	98.0	79	86.0
102	4269	61	5600	73	177.8	120.0	19.0	62	124.5	100	102.0
102 ¹ / ₂	7470	107	5000	92	212.8	148.0	22.0	77	149.0	122	112.0
103	12094	172	4400	105	239.7	178.0	22.0	91	174.0	140	126.0
103 ¹ / ₂	18496	264	3900	123	279.4	206.0	27.0	106	200.0	162	137.0
104	30590	436	3600	146	317.5	234.0	27.0	120	234.0	192	154.5
104 ¹ / ₂	41971	598	3200	171	346.1	262.0	27.0	135	263.0	214	350.0
105	56560	806	2900	183	388.9	298.0	38.0	153	293.0	239	185.0
105 ¹ / ₂	73985	1054	2650	205	425.5	316.0	38.0	168	325.0	267	235.5
106	90345	1287	2450	230	457.2	338.0	25.0	188	356.0	295	188.0
107	135160	1926	2150	270	527.0	369.0	28.5	221	406.0	342	220.5

Tamaño Tamaño Size	GL1					GL2				
	L max	T max		gap		L max	T max		gap	
		each	total	min	max		each	total	min	max
101	85	1.3	2.6	7.5	10	--	--	--	--	--
101 ¹ / ₄	99	5.0	10.0	7.5	13	201	6	12	7.5	41
101 ¹ / ₂	117	10.0	20.0	7.5	19	226	23	46	7.5	54
102	151	9.0	18.0	7.5	27	266	27	54	7.5	62
102 ¹ / ₂	199	17.0	34.0	9.5	45	301	34	68	9.5	77
103	234	21.0	42.0	9.5	52	333	36	72	9.5	81
103 ¹ / ₂	283	30.0	60.0	11.0	71	376	45	90	11.0	102
104	320	33.0	66.0	14.0	80	430	53	106	14.0	121
104 ¹ / ₂	368	41.0	82.0	16.0	98	836	60	120	16.0	136
105	430	53.0	106.0	18.0	124	523	67	134	18.0	153
105 ¹ / ₂	463	58.0	116.0	18.0	127	645	78	156	18.0	174
106	492	53.0	106.0	21.0	116	563	83	166	21.0	187
107	588	62.0	124.0	27.0	146	664	98	196	27.0	223

ACOPLAMENTOS DE ENRENAGENS **POR** **Deslocamento axial**
ACOPLAMIENTOS DE ENGRANAJES **ESP** **Desplazamiento axial**
GEAR COUPLINGS **ENG** **Slide couplings**

Acoplamento com posicionamento axial ajustável.

Aplicação: Em certos tipos de equipamentos acionados as distâncias entre os eixos variam durante o funcionamento, solicitando um acoplamento com posicionamento axial ajustável, e este acoplamento é projetado para esse propósito.

Acoplamento con desplazamiento axial.

Aplicaciones: En algunos tipos de mandos, las distancias entre puntas de ejes varían durante el funcionamiento del equipo, requiriendo un acoplamiento con desplazamiento axial. El diseño de estos acoplamientos cumplen este propósito.

Adjustable axial position coupling.

Application: In certain types of equipment drives, shaft to shaft distance varies during equipment operation requiring an axial travel type of coupling. The design of the adjustable axial position couplig suits this purpose.

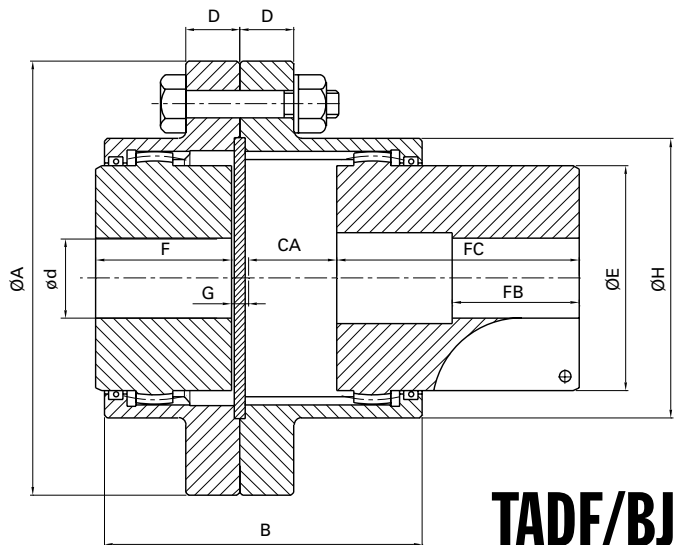
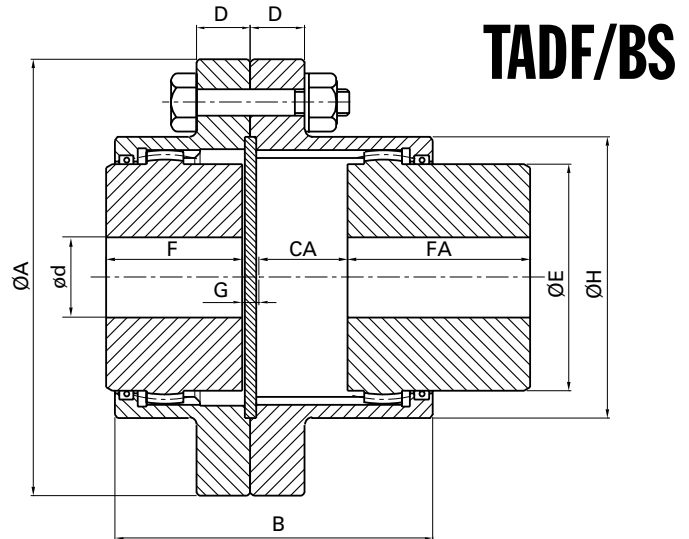

Tamanho Tamaño Size	Torque Nm	HP/ 100 rpm	rpm max	ø d max	A	B	D	F	H	E	CA min	CA max	FA	FC	FB	G
101½	2348	34	6500	60	152.4	110.0	19	49	98.0	79	1.5	39.5	64	85.0	44.5	4
102	4269	61	5600	73	177.8	136.0	19	62	124.5	100	1.5	50.0	77	107.0	57.0	4
102½	7470	107	5000	92	212.8	175.5	22	77	149.0	122	2.5	63.0	95	112.5	70.0	6
103	12094	172	4400	105	239.7	210.0	22	91	174.0	140	3.0	75.0	120	147.5	82.5	6
103½	18496	264	3900	123	279.4	232.0	27	106	200.0	162	3.0	80.0	120	191.5	95.0	6
104	30590	436	3600	146	317.5	253.0	27	120	234.0	192	3.0	86.0	140	271.0	108.0	6
104½	41971	598	3200	171	346.1	278.0	27	135	263.0	214	4.0	100.0	148	318.5	120.0	8
105	56560	806	2900	183	388.9	311.0	38	153	293.0	239	4.0	111.0	162	326.0	133.5	8
105½	73985	1054	2650	205	425.5	334.0	38	168	325.0	267	4.0	119.0	178	335.0	139.0	8
106	90345	1287	2450	230	457.2	342.0	25	188	356.0	295	4.0	129.0	195	418.5	159.0	8



ACOPLAMENTOS DE ENGRENAGENS **POR** **Com desconexão**
ACOPLAMIENTOS DE ENGRANAJES **ESP** **Acople y desacople**
GEAR COUPLINGS **ENG** **Disconnect**

TADF/BSE

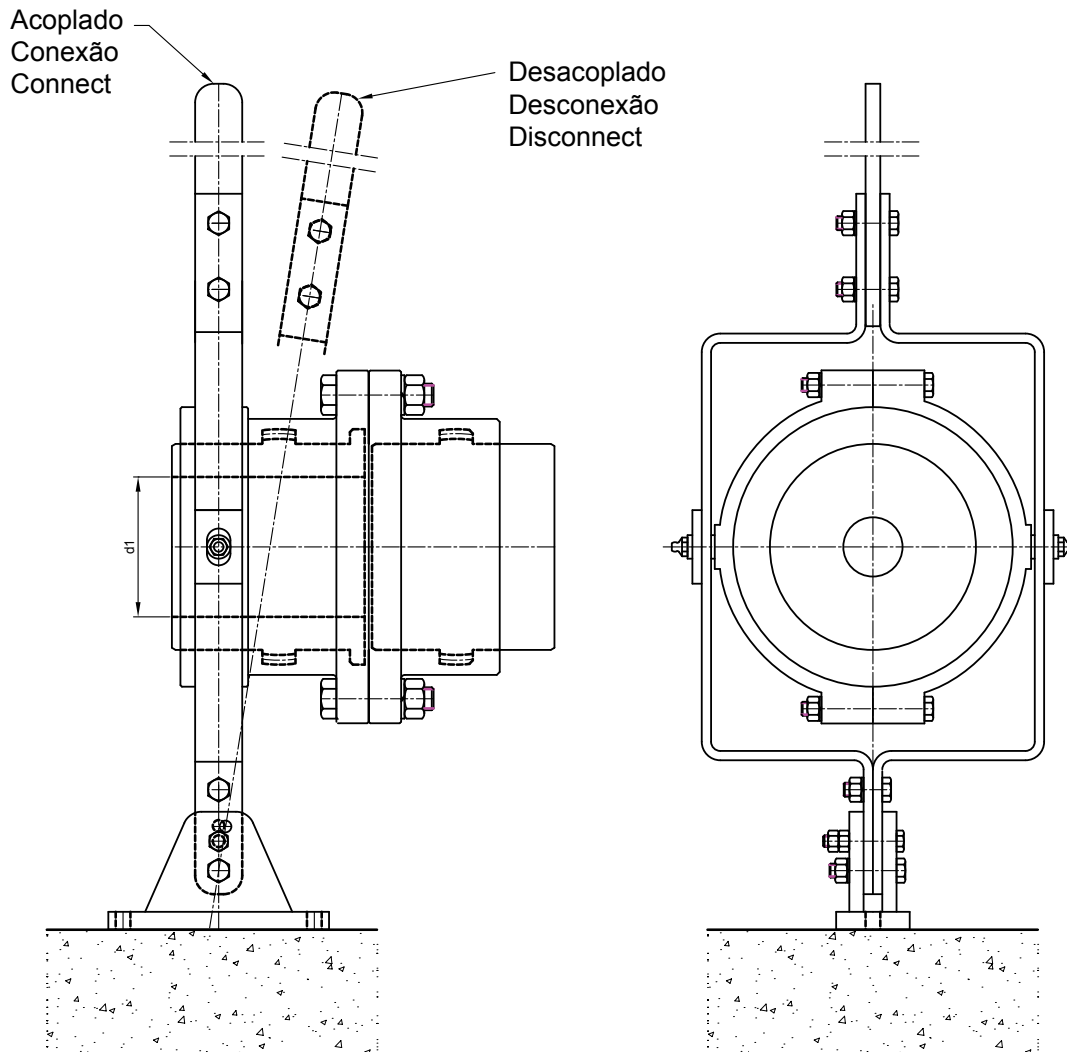

Tamanho Tamaño Size	Torque Nm	HP/ 100 rpm	rpm max*	d1 max
101½	2348	34	3200	60
102	4269	61	2450	73
102½	7470	107	2000	92
103	12094	172	1650	105
103½	18496	264	1530	123
104	30590	436	1200	146
104½	41971	598	1060	171
105	56560	806	950	183
105½	73985	1054	860	205
106	90345	1287	830	230

Projetado para aplicações que necessitam de uma conexão e desconexão rápida do acionamento. Este modelo de acoplamento é normalmente utilizado em acionamentos auxiliares (geralmente em turbinas ou motores) para substituir o motor principal.

Diseñado para aplicaciones que requieren una función de conexión y desconexión rápida. Estos acoplamientos son normalmente usados en conductores con una palanca movilizadora primaria (normalmente una turbina o motor) para resguardar el motor principal.

Designed for applications requiring a quick connect and disconnect function. This coupling is commonly used on drives with an auxiliary prime mover (usually a turbine or engine) to back up the main drive motor.

*Consulte nossa fábrica para mais altas velocidades y dimensões /
 Consulte a fábrica por velocidades más altas y otras dimensiones/
 Consult factory for higher speeds and measurements.

ACOPLAMENTOS DE ENGRENAGENS **POR** Disco ou polia de freio
ACOPLAMIENTOS DE ENGRANAJES **ESP** Disco o polea de freno
GEAR COUPLINGS **ENG** Brakewheel or disc brake

TADF/BDF

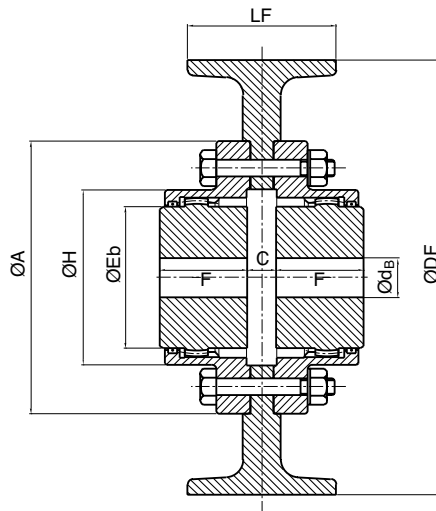
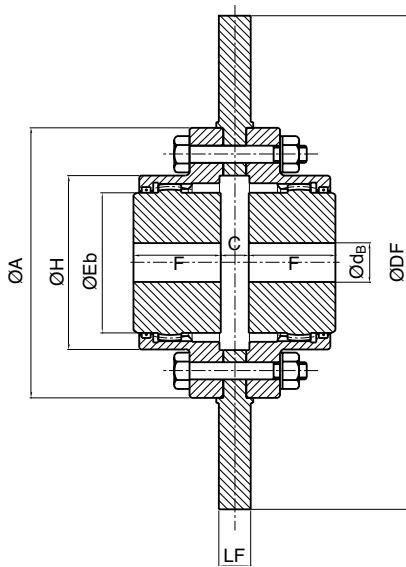

TADF/BCF

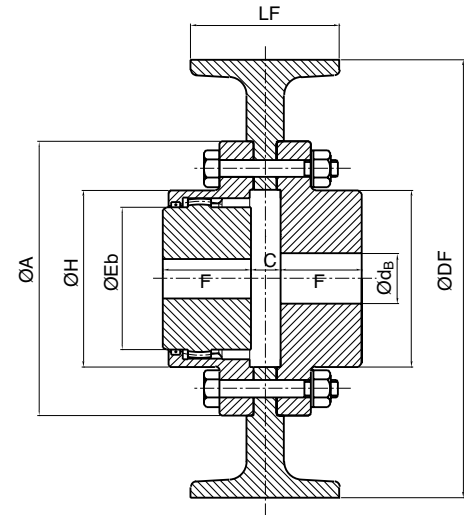

TADSF/BCF

TADF/ADF

Vedação por câmara redentora
 Cierre laberíntico
 Labyrinth Seal

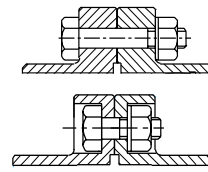
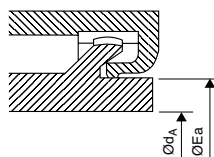

Parafusos / Bulones / Bolts

Os acoplamentos Tecnon podem ser fornecidos com parafusos expostos ou embutidos.

Los acoplamientos Tecnon pueden ser suministrados con bulones expuestos o bulones embutidos.

Couplings may be furnished with exposed bolts or shrouded bolts.

Tamanho Tamaño Size	Torque Nm	HP/ 100 rpm	rpm max	Ø dB max	Ø dA max	A	D	F	H	Eb	Ea	Df	Lf	C
101	1140	16	8000	44	37	115.9	14.0	41	76.0	58	48	Depende do freio Depende del freno Depends on brake		
101¼	1756	25	7250	47	43	130.0	16.0	43	83.0	64	55			
101½	2348	34	6500	60	54	152.4	19.0	49	98.0	79	69			
102	4269	61	5600	73	71	177.8	19.0	62	124.5	100	92			
102½	7470	107	5000	92	84	212.8	22.0	77	149.0	122	109			
103	12094	172	4400	105	95	239.7	22.0	91	174.0	140	123			
103½	18496	264	3900	123	105	279.4	27.0	106	200.0	162	140			
104	30590	436	3600	146	120	317.5	27.0	120	234.0	192	168			
104½	41971	598	3200	171	135	346.1	27.0	135	263.0	214	182			
105	56560	806	2900	183	160	388.9	38.0	153	293.0	239	210			
105½	73985	1054	2650	205	175	425.5	38.0	168	325.0	267	235			
106	90345	1287	2450	230	190	457.2	25.0	188	356.0	295	250			
107	135160	1926	2150	270	---	527.0	28.5	221	406.0	342	---			



ACOPLAMENTOS DE ENGRENAGENS **POR** Mill motor com polia de freio
ACOPLAMIENTOS DE ENGRANAJES **ESP** Mill motor con patea de freno
GEAR COUPLINGS **ENG** Mill motor brakewheel disc

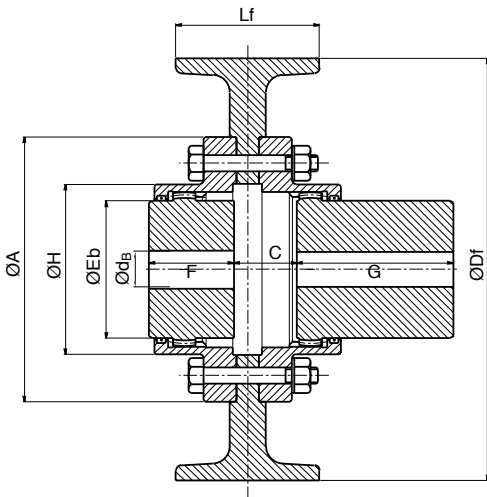

TADF/BMMCF

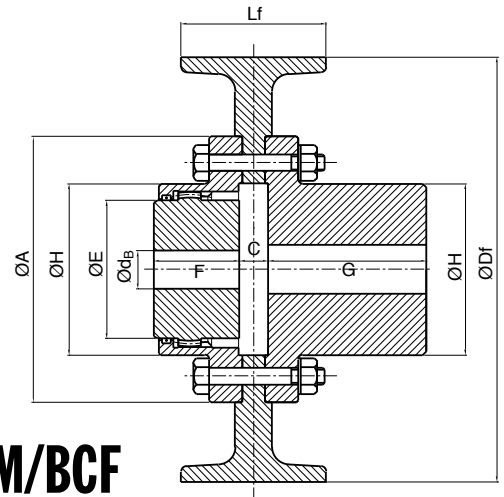

TADSFMM/BCF

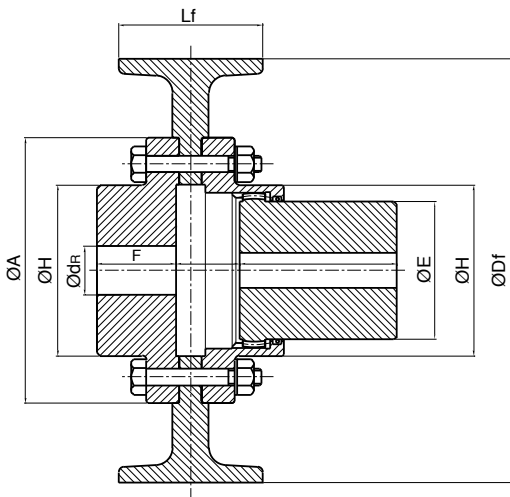

TADSF/BMMCF

Parafusos / Bulones / Bolts

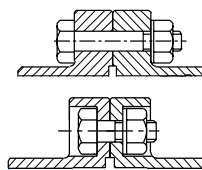

Os acoplamentos Tecnon podem ser fornecidos com parafusos expostos ou embutidos.
 Los acoplamentos Tecnon pueden ser suministrados con bulones expuestos o bulones embutidos.
 Couplings may be furnished with exposed bolts or shrouded bolts.

Tamanho Tamaño Size	Torque Nm	HP/ 100 rpm	rpm max	σ dB max	σ dA max	σdR	A	D	F	H	G	J	Eb	Ea	C	Df	Lf
101½	2348	34	6500	60	54	74	152.4	19	49	98.0	92.5	45.5	79	69	Determinado pelo eixo cônico Determinado por el eje cónico Determined by shaft mill motor	Depende do freio Depende del freno Depends on brake	
102	4269	61	5600	73	71	91	177.8	19	62	124.5	106.0	58.0	100	92			
102½	7470	107	5000	92	84	112	212.8	22	77	149.0	125.0	71.0	122	109			
103	12094	172	4400	105	95	131	239.7	22	91	174.0	136.0	86.0	140	123			
103½	18496	264	3900	123	105	151	279.4	27	106	200.0	153.0	100.0	162	140			
104	30590	436	3600	146	120	177	317.5	27	120	234.0	178.5	114.0	192	168			
104½	41971	598	3200	171	135	207	346.1	27	135	263.0	152.5	127.0	214	182			
105	56560	806	2900	183	160	224	388.9	38	153	293.0	257.0	145.0	239	210			
105½	73985	1054	2650	205	175	250	425.5	38	168	325.0	262.0	153.0	267	235			



ACOPLAMENTOS DE ENGRENAGENS **Polia de freio fixa**
ACOPLAMIENTOS DE ENGRANAJES **Polea de freno fija**
GEAR COUPLINGS **Fixed brakewheel**

TADF/BCFF

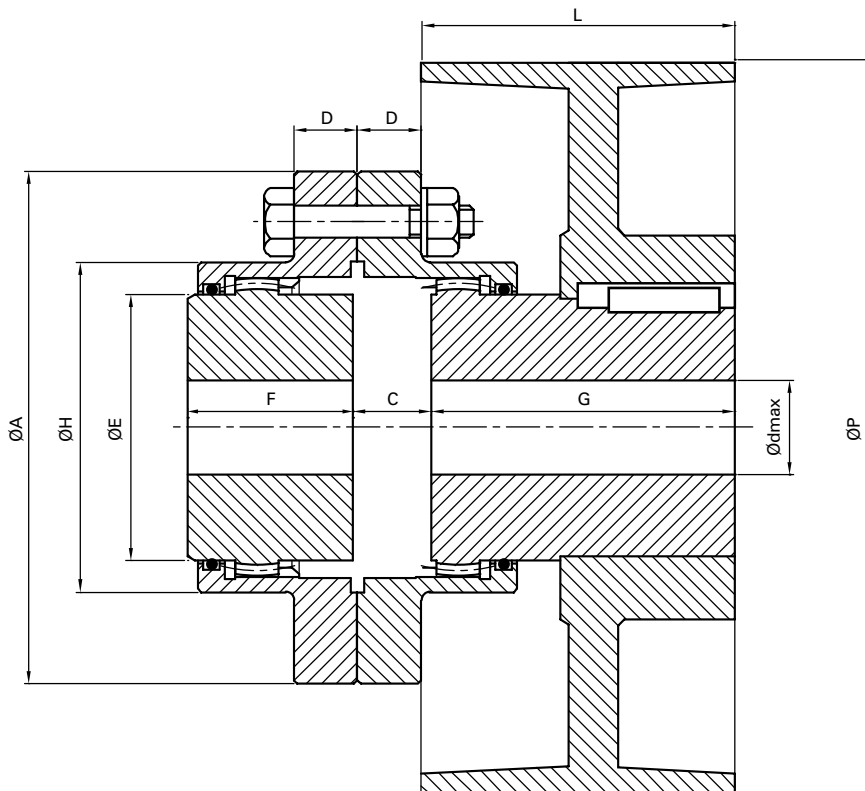

Tamaño Tamaño Size	Torque Nm	rpm max	ø d max	A	D	F	H	E	C	L	G	Polia Polea Pole
101 ¹ / ₂	2348	2860	60	152.4	19	49	98	79	27.0	83	90.0	8"
102	4269	2290 1760	73	177.8	19	62	124	100	27.0	95 146	92.5 106.0	10" 13"
102 ¹ / ₂	7470	2290 1760 1430	92	212.7	22	77	149	122	28.0	95 146 172	107.0 123.0 125.0	10" 13" 16"
103	12094	1430	105	239.7	22	91	174	140	33.5	172	133.0	16"



ACOPLAMENTOS DE ENRENAGENS **POR** Para tambores de cabo
ACOPLAMIENTOS DE ENGRANAJES **ESP** Para tambores a cable
GEAR COUPLINGS **ENG** For rope drums

TAPG

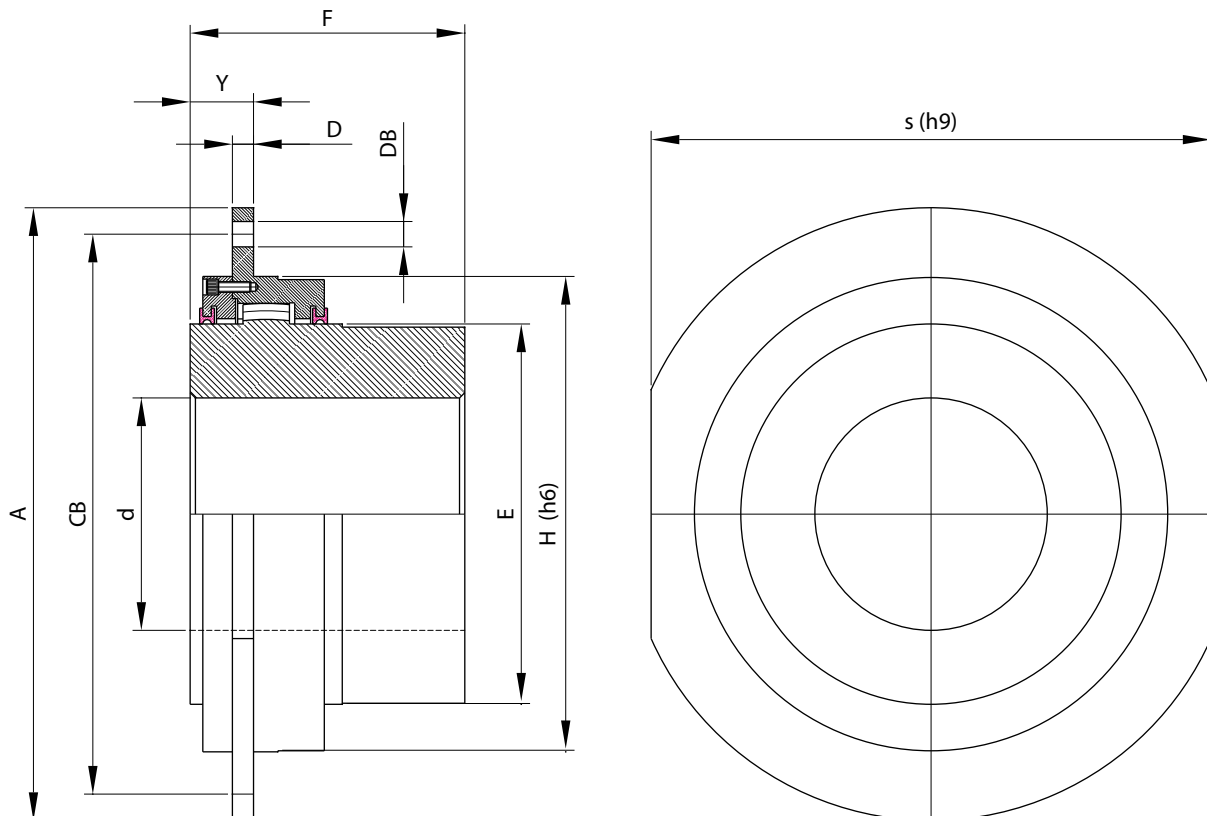

Tamaño Tamaño Size	Torque Nm	Carga radial (máx) N	(1) Ød max	F	A	H	E	s	Y	D	CB	Db (mm)			Flange Brida Nº	(2) Peso Kg	Graxa Aceite Oil dm ³
												Serie (*)					
												F	M	J			
220	26700	39700	95	125	340	220	135	300	45	15	300	15	18	19	1	25	0.05
240	32500	44200	110	130	360	240	160	320	45	15	320	15	18	19	1	32	0.06
260	44500	54000	125	145	380	260	185	340	45	15	340	19	18	19	1	42	0.08
280	58500	66200	145	170	400	280	210	360	45	15	360	19	18	19	1	55	0.11
310	79000	81400	160	175	420	310	230	380	60	20	380	24	18	19	1	76	0.14
340	93000	111000	180	185	450	340	255	400	60	20	400	24	23	24	1	80	0.15
400	139000	143000	200	220	510	400	290	460	60	20	460	24	23		1	120	0.20
420	158000	157000	220	240	550	420	320	500	60	20	500	24	23	24	1	155	0.30
450	196000	179000	250	260	580	450	360	530	60	20	530	24	23	24	2	195	0.40
530	305000	221000	275	315	650	530	400	580	65	25	600	24	23	24	2	295	0.60
560	390000	325000	300	350	680	560	440	600	65	25	630	24	23	24	3	380	0.60
600	460000	380000	330	380	710	600	480	640	81	35	660	28	28	28	4	460	0.90
670	600000	420000	360	410	780	670	520	700	81	35	730	28	28	28	4	570	1.10
730	880000	500000	415	450	850	730	600	760	81	35	800	28	28	28	4	800	1.50

(*) Furado conforme / Perforado según / Drilled according: (F) Flender, (M) Maina, (J) Jaure/Malmedia

(1) Máximo furo para chaveta conforme DIN 6885 / Máximo agujero para chavetero según DIN 6885 / DIN 6885 key max hole

(2) Peso de referência do acoplamento com furo médio / Peso referido a acople con agujero medio / Coupling weight with mid hole

ACOPLAMENTOS DE ENGRENAGENS **POR** Para tambores de cabo
ACOPLAMIENTOS DE ENGRANAJES **ESP** Para tambores a cable
GEAR COUPLINGS **ENG** For rope drums

TAPG (cont.)

Bridas / Flanges

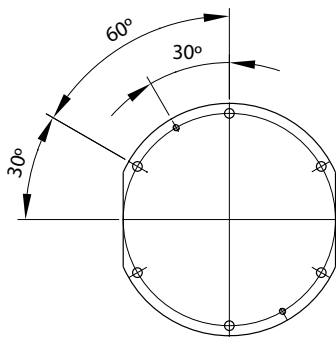

[1]
 Disposição dos furos (6)
 Disposición de agujeros (6)
 Hole pattern (6)

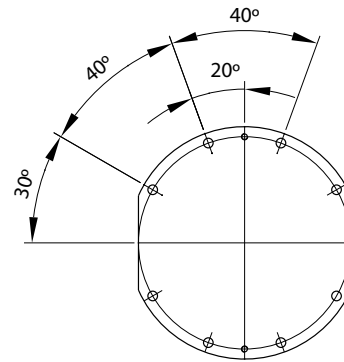

[2]
 Disposição dos furos (8)
 Disposición de agujeros (8)
 Hole pattern (8)

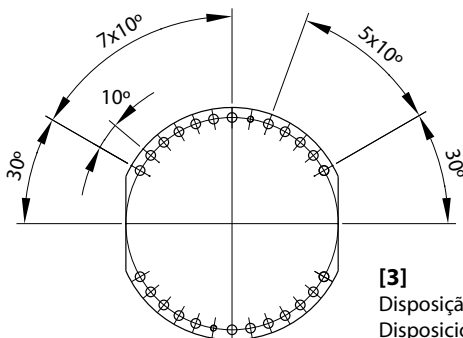

[3]
 Disposição dos furos (24)
 Disposición de agujeros (24)
 Hole pattern (24)

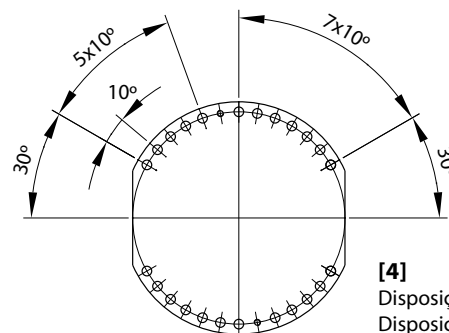

[4]
 Disposição dos furos (24)
 Disposición de agujeros (24)
 Hole pattern (24)

Flange do tambor Brida del tambor Drum flange

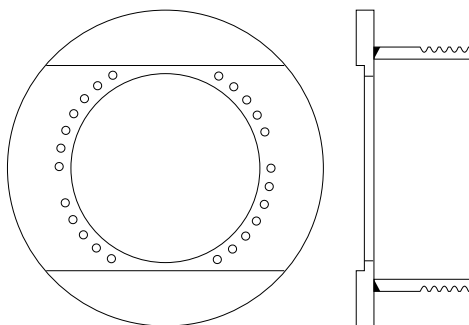

Seleção do acoplamento Selección del acoplamiento Gear coupling selection

Dados do carga / Datos de carga / Load data:

T_n = Max Torque on the drum	[kNm]
Q = Max radial load on the gear coupling	[kg]
D = Shaft diameter	[mm]
FS = Service factor	[-]

Verifique que / Verify that:

Gear coupling nominal Torque	T_k [kNm] ≥ T _n x FS
Max gear coupling radial Torque	Q_k [kg] ≥ Q
Max Gear coupling bore	d [mm] ≥ D

EQUIVALENCIA DE TAMAÑOS CON DISTINTAS MARCAS

	220	240	260	280	310	340	400	420	450	530	560	600	670	730
TECNON	220	240	260	280	310	340	400	420	450	530	560	600	670	730
FLENDER	198	230	255	290	315	342	375	415	465	505	545	585	640	730
MAINA	22	24	26	28	31	34	40	42	45	53	56	60	67	73



ACOPLAMIENTOS DE ROLETES **POR** Para tambores de cabo
ACOPLAMIENTOS DE BARRILETE **ESP** Para tambores a cable
DRUM COUPLINGS **ENG** For rope drums

TAB

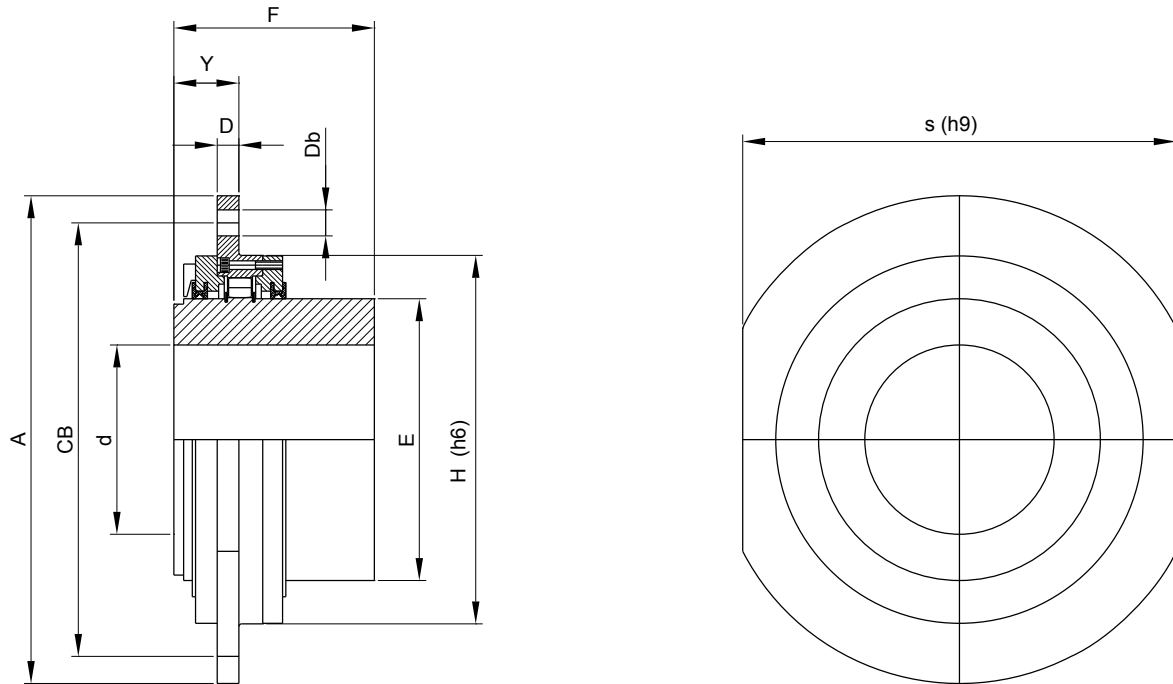

Tamaño Tamaño Size	Torque Nm	Carga radial max N	(1) Ød max	F	A	H	E	S	Y	D	CB	Db	Flange Brida N*	(2) Peso Weight Kg	Grasa Grasa Oil dm ³
160	4500	14500	65	95	250	160	95	220	42	12	220	15	1	11	0.04
180	6000	16500	75	100	280	180	110	250	42	12	250	15	1	14	0.05
200	7500	18500	85	110	320	200	125	280	45	15	280	19	1	20	0.06
220	9000	20000	95	125	340	220	140	300	45	15	300	19	1	24	0.07
240	15500	31000	105	130	360	240	160	320	45	15	320	19	1	29	0.08
260	19500	35000	120	145	380	260	180	340	45	15	340	19	1	34	0.11
280	24000	38500	135	170	400	280	200	360	45	15	360	19	1	45	0.14
310	28000	42000	145	175	420	310	220	380	45	15	380	19	1	52	0.15
340	38000	49000	175	185	450	340	260	400	60	20	400	24	1	70	0.20
400	61400	92000	195	220	510	400	290	460	60	20	460	24	1	110	0.25
420	70000	115000	205	240	550	420	310	500	60	20	500	24	1	130	0.30
450	120000	125000	230	260	580	450	350	530	60	20	530	24	2	159	0.40
530	180000	150000	280	315	650	530	415	580	65	25	600	24	2	254	0.60
545	250000	221000	305	330	665	545	428	590	65	25	615	24	3	290	0.60
560	310000	250000	300	350	680	560	445	600	65	25	630	24	3	310	0.60
600	400000	300000	315	380	710	600	475	640	81	35	660	28	3	395	0.90
670	500000	340000	355	410	780	670	535	700	81	35	730	28	3	520	1.10
730	685000	380000	400	450	850	730	600	760	81	35	800	28	3	685	1.50

(1) Máximo furo para chaveta conforme DIN 6885 / Máximo agujero para chavetero según DIN 6885 / DIN 6885 key max hole

(2) Peso de referência do acoplamento com furo médio / Peso referido a acople con agujero medio / Coupling weight with mid hole

ACOPLAMIENTOS DE ROLETES **POR** Para tambores de cabo
ACOPLAMIENTOS DE BARRILETE **ESP** Para tambores a cable
DRUM COUPLINGS **ENG** For rope drums

TAB

Bridas / Flanges

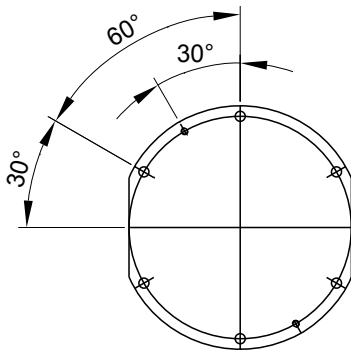

[1]
 disposição dos furos(6)
 Disposición de agujeros (6)
 Hole pattern (6)

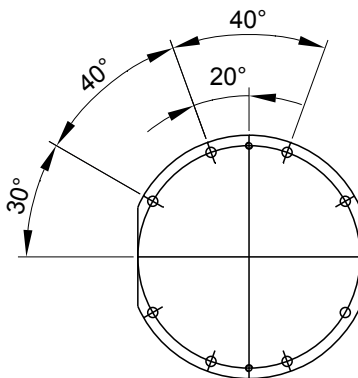

[2]
 disposição dos furos(8)
 Disposición de agujeros (8)
 Hole pattern (8)

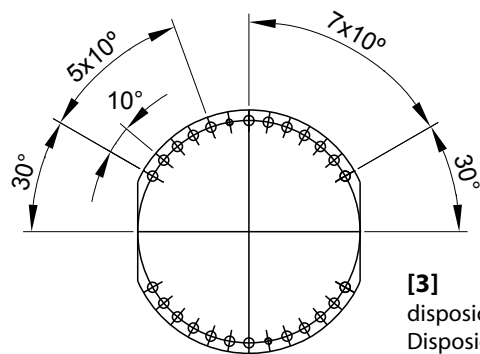

[3]
 disposição dos furos(24)
 Disposición de agujeros (24)
 Hole pattern (24)

Flange do tambor Brida del tambor Drum flange

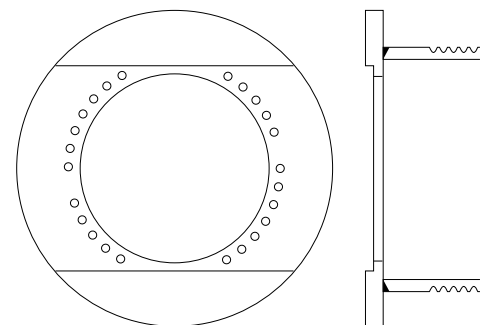

Equivalência dos tamanhos com marcas diferentes/Equivalencia de tamaños con distintas marcas/Equivalence of size with different brands

TECNON	160	180	200	220	240	260	280	310	340	400	420	450	530	545	560	600	670	730
JAURE	25	50	75	100	130	160	200	300	400	500	600	1000	1500	2100	2600	3400	4200	6200
MALMEDIE	0.25	0.5	0.75	1	1.3	1.6	2	3	4	-	6	10	15	21	26	34	42	62
GOSAN	65	75	85	95	105	120	135	145	175	-	205	230	280	-	300	315	355	400



ACOPLAMENTOS DE ENRENAGENS **POR** **Com pino de cisalhamento**
ACOPLAMIENTOS DE ENGRANAJES **ESP** **Perno fusible**
GEAR COUPLINGS **ENG** **Shear pin**

TADF/BPF

Acoplamentos de pino fusível são utilizados para desconectar fisicamente um equipamento que está sendo acionado quando ocorrer uma sobrecarga. Isto protege o equipamento principal de transmissão de danos que poderiam resultar em uma perda de tempo e produção.

Los acoplamientos con perno fusible son usados para desconectar físicamente el equipo conductor y el conducido cuando ocurre una sobrecarga. Esto protege de daños al equipo de la transmisión crítica de potencia que podría ocasionar pérdida de tiempo y producción.

Shear pin couplings are used to physically disconnect the driving and driven equipment when an overload occurs. This protects the critical power transmission equipment from damage which could result in downtime and lost production.

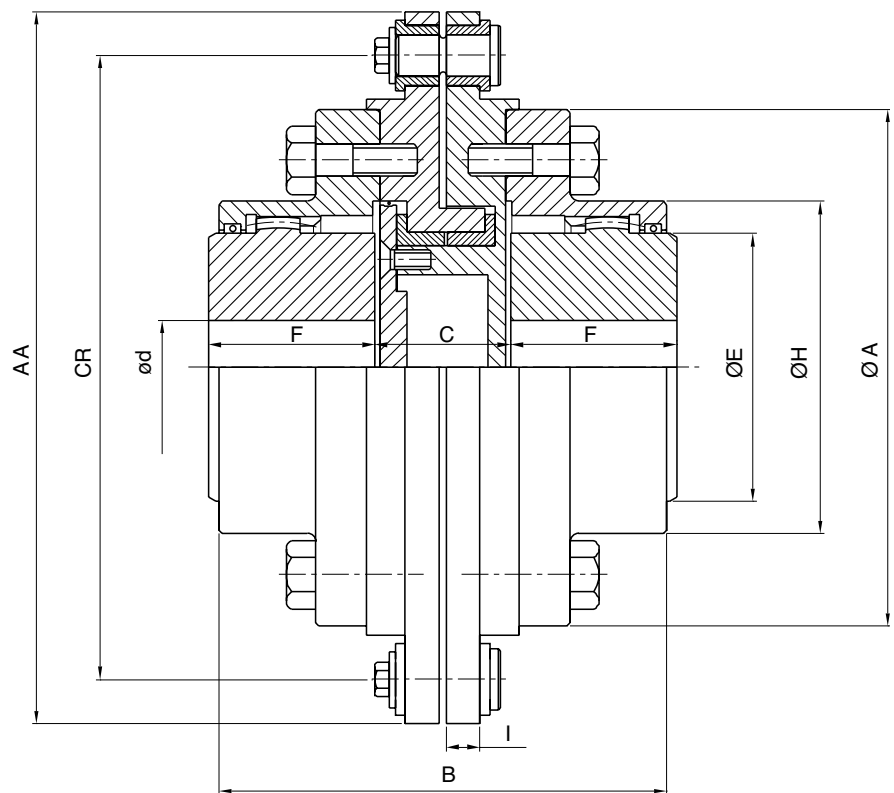

Tamanho Tamaño Size	Torque Nm	HP/ 100 rpm	rpm max	ø d max	A	AA	B	D	F	H	E	C	CR	I	Peso Weight Kg
101	1140	16	8000	47	115.9	173	105	14	41	76.0	58	34.5	148	10	11.61
101½	2348	34	6500	60	152.4	210	132	19	49	98.0	79	40.0	184	10	14.94
102	4269	61	5600	73	177.8	235	163	19	62	124.5	100	46.0	210	10	36.84
102½	7470	107	5000	92	212.8	318	191	22	77	149.0	122	48.0	267	10	62.65
103	12094	172	4400	105	239.7	338	225	22	91	174.0	140	52.0	294	12	81.37
103½	18496	264	3900	123	279.4	378	258	27	106	200.0	162	58.0	334	12	124.27
104	30590	436	3600	146	317.5	416	286	27	120	234.0	192	58.0	372	12	163.67
104½	41971	598	3200	171	346.1	450	314	27	135	263.0	214	60.0	400	12	214.90
105	56560	806	2900	183	388.9	483	378	38	153	293.0	239	88.0	438	25	342.57
105½	73985	1054	2650	205	425.5	533	394	38	168	325.0	267	88.0	482	25	454.88
106	90345	1287	2450	230	457.2	591	416	25	188	356.0	295	88.0	521	25	526.73

ACOPLAMENTOS DE ENGRENAGENS **POR** **Isolante de corrente elétrica**
ACOPLAMIENTOS DE ENGRANAJES **ESP** **Aislantes eléctricos**
GEAR COUPLINGS **ENG** **Electrical insulated**

TADF/BI

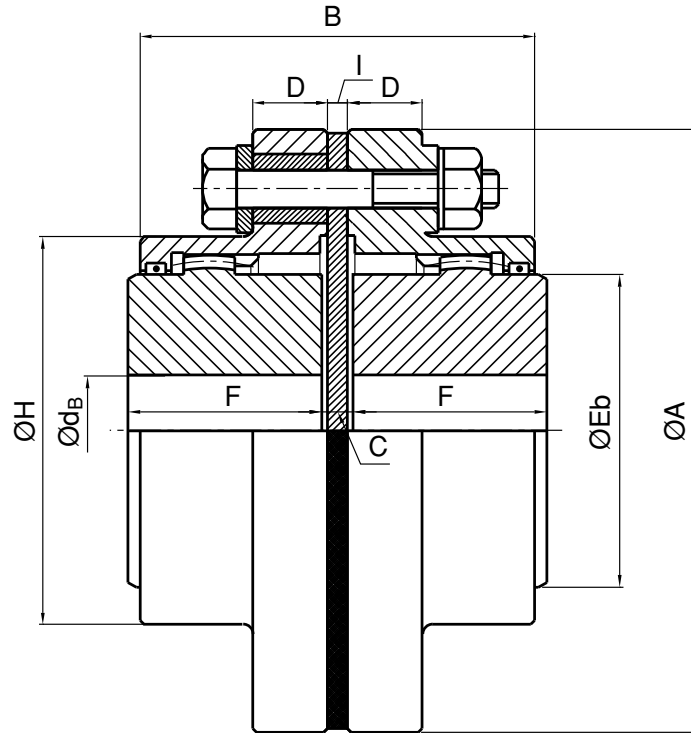

TADF/AI

Vedação por câmara redentora
 Cierre laberíntico
 Labyrinth Seal

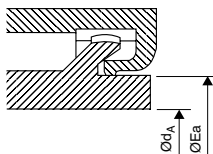

Fabricados em:

- Aço SAE 1045 tratados termicamente a uma dureza de 240-260 Brinell.
- Aço SAE 4140 beneficiados e nitretados a uma dureza de 45-50 Rc.

Fabricados en:

- Acero SAE 1045 tratados termicamente a uma dureza de 240-260 Brinell.
- Acero SAE 4140 bonificados y nitruados a 45-50 Rc.

Manufactured in:

- SAE 1045 steel, heat treated with a hardness Brinell 240-260.
- SAE 4140 steel, boron treated and nitrided to 45-50 Rc.

**Parafusos
Bulones
Bolts**

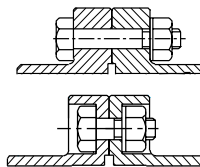

Os acoplamentos Tecnon podem ser fornecidos com parafusos expostos ou embutidos.

Los acoplamientos Tecnon pueden ser suministrados con bulones expuestos o bulones embutidos.

Couplings may be furnished with exposed bolts or shrouded bolts.

Tamanho Tamaño Size	Torque Nm	HP/ 100 rpm	rpm max	ø dB max	ø dA max	A	B	D	F	H	I	Eb	Ea	C gap
101	1140	16	8000	44	37	115.9	76	14.0	41	76.0	4	58	48	7
101¼	1756	25	7250	47	43	130.0	87	16.0	43	83.0	4	64	55	7
101½	2348	34	6500	60	54	152.4	99	19.0	49	98.0	4	79	69	7
102	4269	61	5600	73	71	177.8	124	19.0	62	124.5	4	100	92	7
102½	7470	107	5000	92	84	212.8	152	22.0	77	149.0	4	122	109	9
103	12094	172	4400	105	95	239.7	182	22.0	91	174.0	4	140	123	9
103½	18496	264	3900	123	105	279.4	210	27.0	106	200.0	4	162	140	10
104	30590	436	3600	146	120	317.5	238	27.0	120	234.0	4	192	168	10
104½	41971	598	3200	171	135	346.1	266	27.0	135	263.0	4	214	182	12
105	56560	806	2900	183	160	388.9	302	38.0	153	293.0	4	239	210	12
105½	73985	1054	2650	205	175	425.5	320	38.0	168	325.0	4	267	235	12
106	90345	1287	2450	230	190	457.2	342	25.0	188	356.0	4	295	250	12
107	135160	1926	2150	270	---	527.0	396	28.5	221	406.0	4	342	---	14



ACOPLAMENTOS DE ENGRENAGENS **POR** **Com espaçador**
ACOPLAMIENTOS DE ENGRANAJES **ESP** **Con espaciador**
GEAR COUPLINGS **ENG** **Spacer type**

TADF/BEH

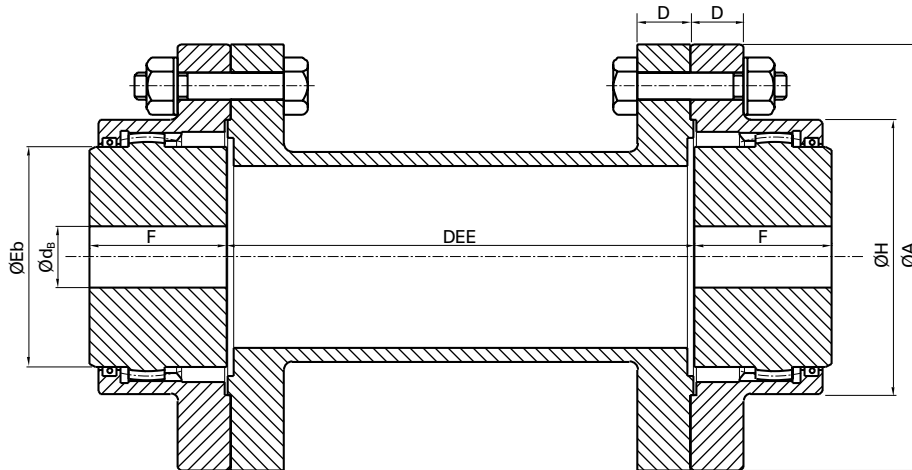

Combinado

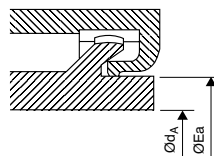
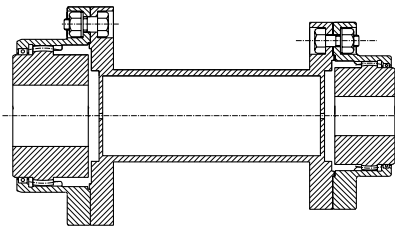

TADF/AEH

Vedação por câmara redentora
Cierre laberíntico
Labyrinth Seal

Fabricados em:

- Aço SAE 1045 tratados termicamente a uma dureza de 240-260 Brinell.
- Aço SAE 4140 beneficiados e nitretados a uma dureza de 45-50 Rc.

Fabricados en:

- Acero SAE 1045 tratados termicamente a uma dureza de 240-260 Brinell.
- Acero SAE 4140 bonificados y nitruados a 45-50 Rc.

Manufactured in:

- SAE 1045 steel, heat treated with a hardness Brinell 240-260.
- SAE 4140 steel, boron treated and nitrided to 45-50 Rc.

Parafusos Bulones Bolts

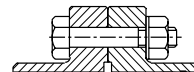

Os acoplamentos Tecnon podem ser fornecidos com parafusos expostos ou embutidos.

Los acoplamientos Tecnon pueden ser suministrados con bulones expuestos o bulones embutidos.

Couplings may be furnished with exposed bolts or shrouded bolts.

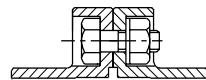

Tamanho Tamaño Size	Torque Nm	HP/ 100 rpm	rpm max	ø dB max	ø dA max	A	D	F	H	Eb	Ea	DEE
101	1140	16	7000	44	37	115.9	14.0	41	76.0	58	48	Segundo a necessidade do cliente Según pedido del cliente On customer demand
101¼	1756	25	6000	47	43	130.0	16.0	43	83.0	64	55	
101½	2348	34	5500	60	54	152.4	19.0	49	98.0	79	69	
102	4269	61	4600	73	71	177.8	19.0	62	124.5	100	92	
102½	7470	107	4000	92	84	212.8	22.0	77	149.0	122	109	
103	12094	172	3600	105	95	239.7	22.0	91	174.0	140	123	
103½	18496	264	3100	123	105	279.4	27.0	106	200.0	162	140	
104	30590	436	2800	146	120	317.5	27.0	120	234.0	192	168	
104½	41971	598	2600	171	135	346.1	27.0	135	263.0	214	182	
105	56560	806	2400	183	160	388.9	38.0	153	293.0	239	210	
105½	73985	1054	2200	205	175	425.5	38.0	168	325.0	267	235	
106	90345	1287	2100	230	190	457.2	25.0	188	356.0	295	250	
107	135160	1926	1800	270	---	527.0	28.5	221	406.0	342	---	

ACOPLAMENTOS DE ENGRENAGENS **POR** **Eixo flutuante**
ACOPLAMIENTOS DE ENGRANAJES **ESP** **Eje flotante**
GEAR COUPLINGS **ENG** **Floating shaft**

TAEF/B

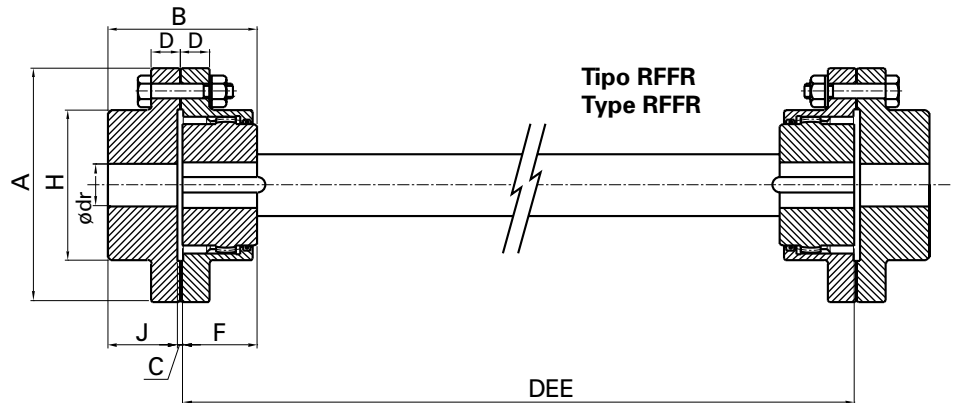

TAEF/A

Vedação por câmara redentora
 Cierre laberíntico
 Labyrinth Seal

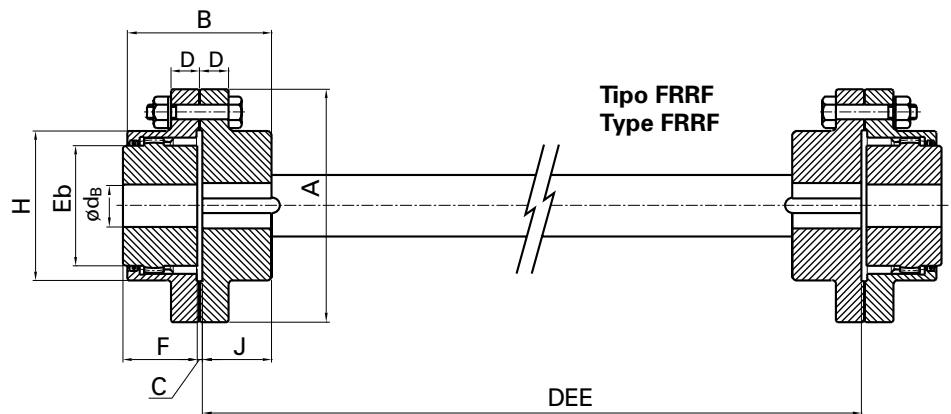
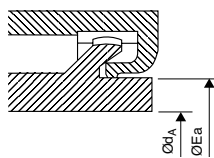

Fabricados em:

- Aço SAE 1045 tratados termicamente a uma dureza de 240-260 Brinell.
- Aço SAE 4140 beneficiados e nitretados a uma dureza de 45-50 Rc.

Fabricados en:

- Acero SAE 1045 tratados termicamente a uma dureza de 240-260 Brinell.
- Acero SAE 4140 bonificados y nitrurados a 45-50 Rc.

Manufactured in:

- SAE 1045 steel, heat treated with a hardness Brinell 240-260.
- SAE 4140 steel, boron treated and nitrided to 45-50 Rc.

Parafusos
Bulones
Bolts

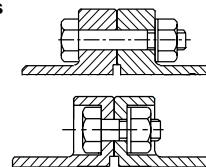

Os acoplamentos Tecnon podem ser fornecidos com parafusos expostos ou embutidos.

Los acoplamientos Tecnon pueden ser suministrados con bulones expuestos o bulones embutidos.

Couplings may be furnished with exposed bolts or shrouded bolts.

Tamanho Tamanho Size	Torque Nm	HP/ 100 rpm	rpm max	ø dB max	ø dA max	ø dr max	A	B	D	F	J	H	Eb	Ea	C	DEE
101	1140	16	8000	44	37	55	115.9	72	14.0	41	34.5	76.0	58	48	3.0	Segundo a necessidade do cliente Según pedido del cliente On customer demand
101¼	1756	25	7250	47	43	61	130.0	83	16.0	43	40.0	83.0	64	55	3.0	
101½	2348	34	6500	60	54	74	152.4	95	19.0	49	45.5	98.0	79	69	3.5	
102	4269	61	5600	73	71	91	177.8	120	19.0	62	58.0	124.5	100	92	3.5	
102½	7470	107	5000	92	84	112	212.8	148	22.0	77	71.0	149.0	122	109	5.5	
103	12094	172	4400	105	95	131	239.7	178	22.0	91	86.0	174.0	140	123	5.5	
103½	18496	264	3900	123	105	151	279.4	206	27.0	106	100.0	200.0	162	140	6.0	
104	30590	436	3600	146	120	177	317.5	234	27.0	120	114.0	234.0	192	168	6.0	
104½	41971	596	3200	171	135	207	346.1	262	27.0	135	127.0	263.0	214	182	8.0	
105	56560	806	2900	183	160	224	388.9	298	38.0	153	145.0	293.0	239	210	8.0	
105½	73985	1054	2650	205	175	250	425.5	316	38.0	168	153.0	325.0	267	235	8.0	
106	90345	1287	2450	230	190	278	457.2	338	25.0	188	164.0	356.0	295	250	8.0	
107	135160	1926	2150	270	---	320	527.0	396	28.5	221	187.5	406.0	342	---	12.0	



ACOPLAMENTOS DE ENRENAGENS **POR** Eixo flutuante
 ACOPLAMIENTOS DE ENGRANAJES **ESP** Eje flotante
 GEAR COUPLINGS **ENG** Floating shaft

TAEF/BF

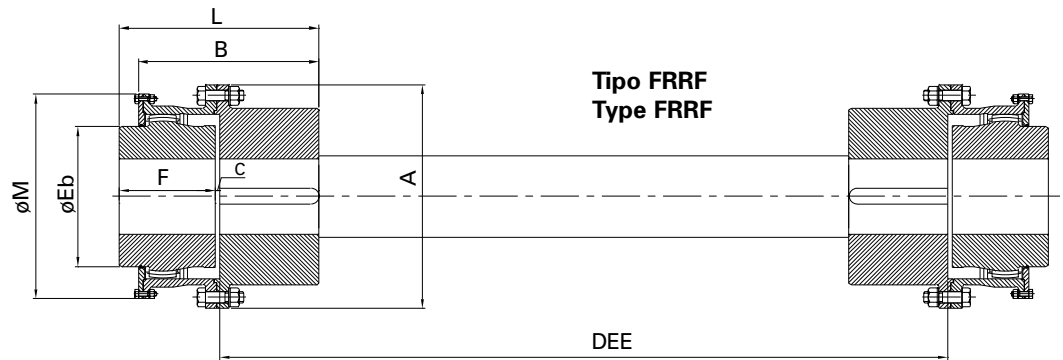
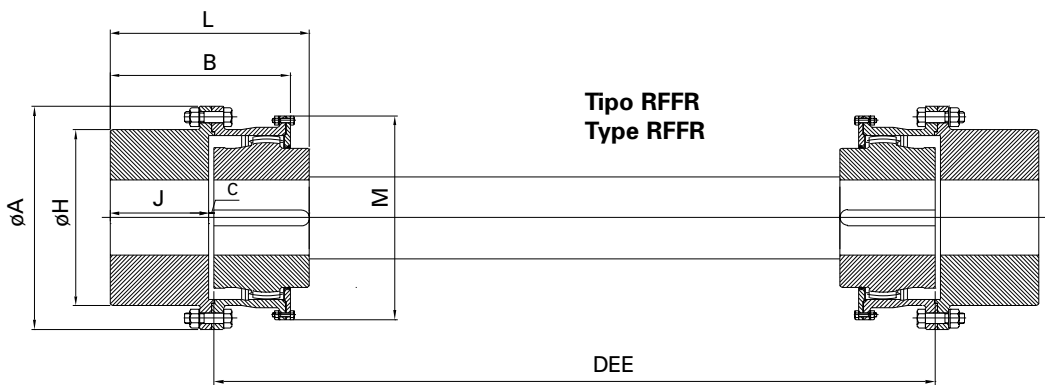

TAEF/AF

Vedação por câmara redentora
Cierre laberíntico
Labyrinth Seal

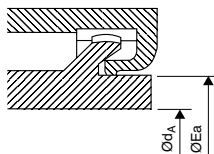

Série aço fundido
SERIE ACERO FUNDIDO
Cast Steel Series

Tamanho Tamaño Size	Torque Nm	HP/ 100 rpm	rpm max	ø dB max	ø dA max	ø dr max	A	B	M	Eb	Ea	L	F	J	H	c gap	DEE
8	287370	4094	1700	214	253	322	590.6	459	540	355	300	508	249	249	462	10	Según necesidad Según pedido On demands
9	390000	5556	1550	243	281	363	660.4	511	600	394	340	565	276	276	516	13	
10	547370	7798	1400	276	318	378	711.0	562	650	455	425	623	305	305	561	13	
11	752630	10723	1300	306	353	417	774.7	616	716	495	465	679	333	333	618	13	
12	957895	13648	1200	336	378	463	838.0	652	776	530	470	717	352	352	680	13	



ACOPLAMENTOS DE ENGRENAGENS **POR** **Eixo flutuante**
ACOPLAMIENTOS DE ENGRANAJES **ESP** **Arbol flotante**
GEAR COUPLINGS **ENG** **Spindle**

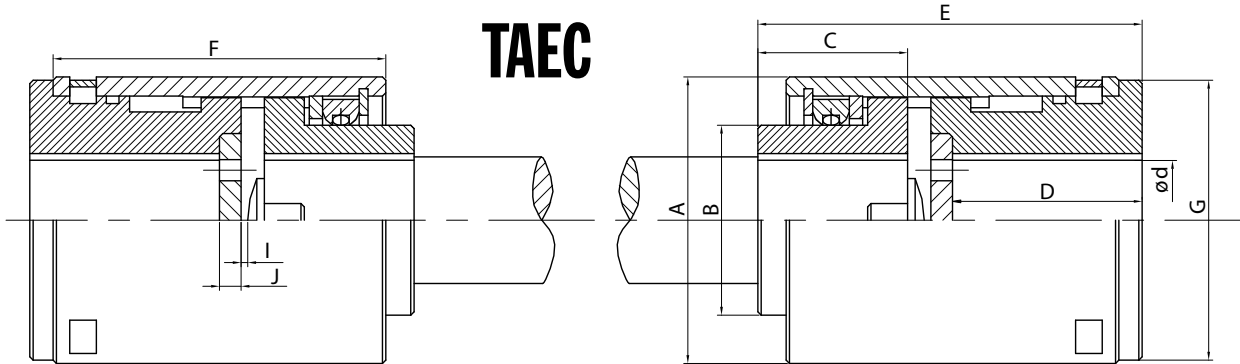

Aplicação: O “TAEC Spindle” geralmente é utilizado em aplicações de médio torque, onde é requerido uma grande capacidade de desalinhamento e também quando o equipamento precisa ser desconectado rapidamente e/ou frequentemente. Aplicações típicas incluem acionamentos auxiliares.

“TAEC Spindle” também pode ser usado em aplicações onde os espaços físicos são limitados.

Aplicación. El árbol flotante TAEC es para aplicaciones de torque medio donde se requiere una alta capacidad de desalineamiento y donde los equipos deban ser desconectados rápida y/o frecuentemente. Aplicaciones típicas: Mandos auxiliares, pin rolls, niveladores, desbobinadores.

Debido al diseño de los acoples que resultan realmente compactos, son ideales cuando la distancia entre centros sea mínima.

Application. The TAEC spindle is for medium torque applications where high misalignment capacity is required and where equipment must be disconnected quickly and/or frequently. Typical application include drives for auxiliary equipment such as levelers, uncoilers, side trimmers, tension and payoff reels, run-out tables, pinch rolls, bridles, flatteners, and scale breakers.

TAEC spindles can also be used on applications where shaft center-to-center spacing is minimal and where diameters are limited.

Modelo	ød max	A	B	C	D	E	F	G	I	J	K
2 3/8	34	60	38	34	45	92	84	59	1.5	5.0	28
2 3/4	40	70	43	38	50	101	92	68	1.5	6.5	32
3	45	76	48	43	57	114	100	75	1.5	6.5	41
3 3/8	49	86	57	45	57	115	101	84	1.5	6.5	45
3 3/4	54	95	64	48	73	136	111	94	1.5	6.5	48
5	76	127	86	62	98	181	140	124	3.0	6.5	57
6	87	152	105	77	114	220	162	149	3.0	9.5	76
7	103	178	130	91	133	252	171	175	3.0	9.5	89
8	124	203	143	106	165	303	195	200	3.0	9.5	102
9	140	229	165	120	181	3335	213	225	3.0	13.0	117
10	159	254	184	135	206	378	235	249	3.0	13.0	130
11 5/8	178	295	216	153	238	431	260	289	5.0	13.0	146
12 5/8	197	320	228	168	260	475	280	314	5.0	13.0	159
14	216	355	254	188	286	521	311	349	5.0	13.0	178
15 3/4	254	400	305	220	343	616	343	394	5.0	13.0	190

Modelo Model	Torque em Nm para o desalinhamento indicado / Torque en Nm para desalineación indicada / Torque capacity (Nm) for misalignment indicated						
	1º	1,5º	2º	3º	4º	5º	6º
2 3/8	669	635	524	379	301	223	156
3	1327	1115	925	658	524	401	268
5	6421	5396	4493	3211	4337	3255	2163
6	10836	9097	7581	5418	4337	3255	2163
7	18918	15886	13244	9454	7570	5674	3779
8	29565	24838	20691	14782	11828	8874	5908
9	44246	37167	30969	22129	17703	13277	8852
10	63644	53466	44547	31828	25462	19097	12731
11 5/8	135114	113498	54001	67557	54046	40534	27023
12 5/8	180709	151825	126530	90377	72295	54224	36153
14	255501	214621	178847	127756	102205	76654	51102
15 3/4	348799	292769	244164	174399	139517	104635	69764

Material SAE 4140 ,Nitruado



ACOPLAMENTOS DE ENGRENAGENS **POR** Duplo engrenamento vertical
ACOPLAMIENTOS DE ENGRANAJES **ESP** Doble compensador vertical
GEAR COUPLINGS **ENG** Vertical double engagement

TADF/BV

TADF/AV

Vedação por câmara redentora
 Cierre laberíntico
 Labyrinth Seal

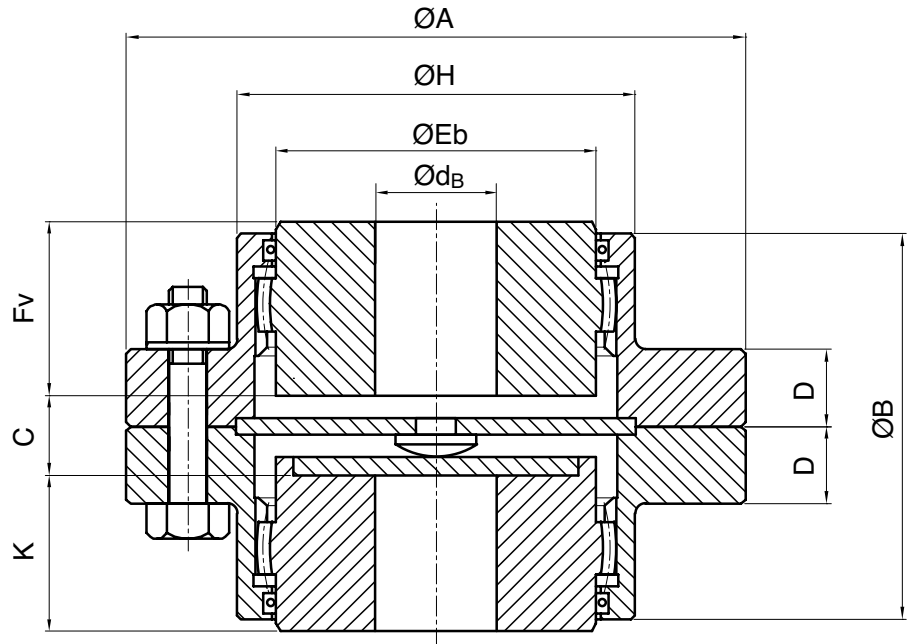
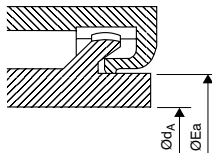

Fabricados em:

- Aço SAE 1045 tratados termicamente a uma dureza de 240-260 Brinell.
- Aço SAE 4140 beneficiados e nitretados a uma dureza de 45-50 Rc.

Fabricados en:

- Acero SAE 1045 tratados termicamente a una dureza de 240-260 Brinell.
- Acero SAE 4140 bonificados y nitruados a 45-50 Rc.

Manufactured in:

- SAE 1045 steel, heat treated with a hardness Brinell 240-260.
- SAE 4140 steel, boron treated and nitrided to 45-50 Rc.

Parafusos Bulones Bolts

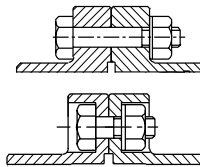

Os acoplamentos Tecnon podem ser fornecidos com parafusos expostos ou embutidos.

Los acoplamientos Tecnon pueden ser suministrados con bulones expuestos o bulones embutidos.

Couplings may be furnished with exposed bolts or shrouded bolts.

Tamaño Tamaño Size	Torque Nm	HP/ 100 rpm	rpm	ø dB max	ø dA max	A	B	D	K	Fv	H	Eb	Ea	C
101	1140	16	8000	44	37	115.9	72.0	14.0	34.5	39.5	76.0	58	11.0	11.0
101¼	1756	25	7250	47	43	130.0	83.0	16.0	35.0	41.5	83.0	64	12.5	12.5
101½	2348	34	6500	60	54	152.4	95.0	19.0	38.5	47.0	98.0	79	15.5	15.5
102	4269	61	5600	73	71	177.8	120.0	19.0	51.0	60.0	124.5	100	16.0	16.0
102½	7470	107	5000	92	84	212.8	148.0	22.0	66.0	74.0	149.0	122	19.0	19.0
103	12094	172	4400	105	95	239.7	178.0	22.0	80.0	88.0	174.0	140	19.0	19.0
103½	18496	264	3900	123	105	279.4	206.0	27.0	94.0	103.0	200.0	162	21.0	21.0
104	30590	436	3600	146	120	317.5	234.0	27.0	106.0	117.0	234.0	192	23.0	23.0
104½	41971	598	3200	171	135	346.1	262.0	27.0	117.0	131.0	263.0	214	30.0	30.0
105	56560	806	2900	183	160	388.9	298.0	38.0	134.5	149.0	293.0	239	30.0	30.0
105½	73985	1054	2650	205	175	425.5	315.0	38.0	150.0	164.0	325.0	267	30.0	30.0
106	90345	1287	2450	230	190	457.2	338.0	25.0	168.8	184.0	356.0	295	32.0	32.0
107	135160	1926	2150	270	---	527.0	396.0	28.5	195.0	213.0	406.0	342	43.5	43.5

ACOPLAMENTOS DE ENGENAGENS **POR** Simple engrenamento vertical
ACOPLAMIENTOS DE ENGRANAJES **ESP** Compensador vertical simple
GEAR COUPLINGS **ENG** Vertical simple engagement

TADSF/BV

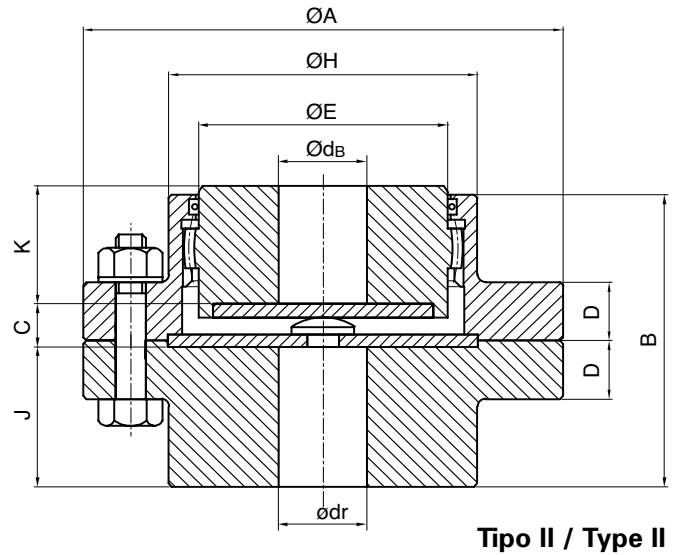
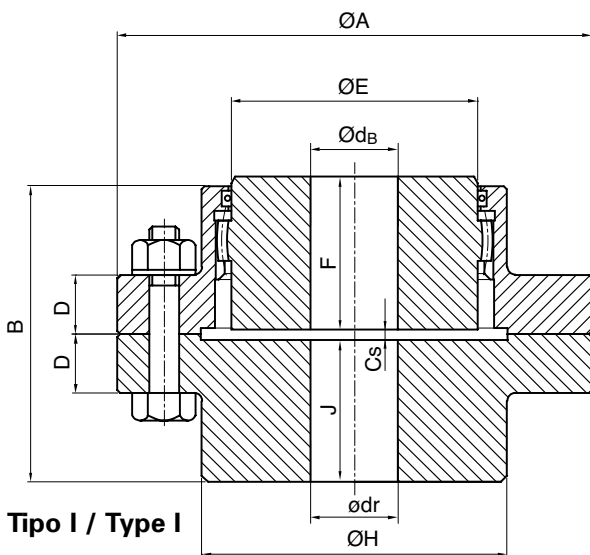

TADSF/AV

Vedação por câmara redentora
 Cierre laberíntico
 Labyrinth Seal

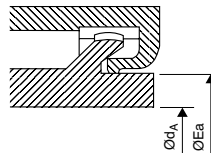

Fabricados em:

- Aço SAE 1045 tratados termicamente a uma dureza de 240-260 Brinell.
- Aço SAE 4140 beneficiados e nitretados a uma dureza de 45-50 Rc.

Fabricados en:

- Acero SAE 1045 tratados termicamente a uma dureza de 240-260 Brinell.
- Acero SAE 4140 bonificados y nitruados a 45-50 Rc.

Manufactured in:

- SAE 1045 steel, heat treated with a hardness Brinell 240-260.
- SAE 4140 steel, boron treated and nitrided to 45-50 Rc.

**Parafusos
 Bulones
 Bolts**

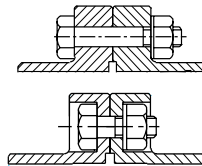

Os acoplamentos Tecnon podem ser fornecidos com parafusos expostos ou embutidos.

Los acoplamientos Tecnon pueden ser suministrados con bulones expuestos o bulones embutidos.

Couplings may be furnished with exposed bolts or shrouded bolts.

Tamanho Tamaño Size	Torque Nm	HP/ 100 rpm	rpm max	ø dB max	ø dA max	ø dr max	A	B	D	J	K	F	H	Eb	Ea	C gap tipo/type I	C gap tipo/type II
101	1140	16	8000	44	37	55	115.9	72.0	14.0	34.5	34.5	41	76.0	58	48	3.0	9.5
101¼	1756	25	7250	47	43	61	130.0	83.0	16.0	40.0	35.0	43	83.0	64	55	3.0	11.0
101½	2348	34	6500	60	54	74	152.4	95.0	19.0	45.5	38.5	49	98.0	79	69	3.5	14.0
102	4269	61	5600	73	66	91	177.8	120.0	19.0	58.0	51.0	62	124.5	100	92	3.5	15.5
102½	7470	107	5000	92	84	112	212.7	148.0	22.0	71.0	66.0	77	149.0	122	109	5.5	16.5
103	12094	172	4400	105	95	131	239.7	178.0	22.0	86.0	80.0	91	174.0	140	123	5.5	16.5
103½	18496	264	3900	123	105	151	279.4	206.0	27.0	100.0	94.0	106	200.0	162	140	6.0	18.0
104	30590	436	3600	146	120	177	317.5	234.0	27.0	114.0	106.0	120	234.0	192	168	6.0	20.0
104½	41971	598	3200	171	135	207	346.1	262.0	27.0	127.0	117.0	135	263.0	214	182	8.0	26.0
105	56560	806	2900	183	160	224	388.9	298.0	38.0	145.0	150.0	153	293.0	239	210	8.0	26.0
105½	73985	1054	2650	205	175	250	425.5	316.0	38.0	153.0	150.0	168	334.0	267	247	8.0	26.0
106	90345	1287	2450	230	190	278	457.2	338.0	25.0	188.0	169.0	188	356.0	295	250	8.0	28.0
107	135160	1926	2150	270	---	320	527.0	396.0	28.5	187.5	195.0	221	406.0	342	---	12.0	38.5



ACOPLAMENTOS DE ENGRENAGENS **POR** Rígido
 ACOPLAMIENTOS DE ENGRANAJES **ESP** Rígido
 GEAR COUPLINGS **ENG** Rigid

TAPA

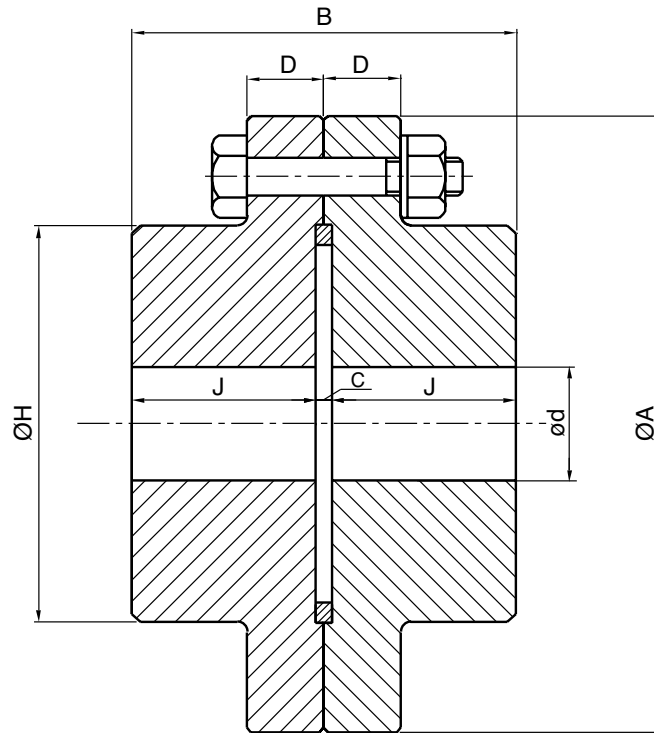

Parafusos Bulones Bolts

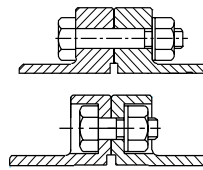

Os acoplamentos Tecnon podem ser fornecidos com parafusos expostos ou embutidos.

Los acoplamientos Tecnon pueden ser suministrados con bulones expuestos o bulones embutidos.

Couplings may be furnished with exposed bolts or shrouded bolts.

Tamaño Tamaño Size	Torque Nm	HP/ 100 rpm	rpm max	ø d max	A	B	D	J	H	C gap	Peso Weight Kg
101	1140	16	8000	55	115.9	72.0	14.0	34.5	76.0	3	4.2
101 1/4	1756	25	7250	61	130.0	83.0	16.0	40.0	83.0	3	5.2
101 1/2	2348	34	6500	74	152.4	95.0	19.0	45.5	98.0	4	8.8
102	4269	61	5600	91	177.8	120.0	19.0	58.0	124.5	4	14.9
102 1/2	7470	107	5000	112	212.8	148.0	22.0	71.0	149.0	6	25.5
103	12094	172	4400	131	239.7	178.0	22.0	86.0	174.0	6	39.5
103 1/2	18496	264	3900	151	279.4	206.0	27.0	100.0	200.0	6	61.0
104	30590	436	3600	177	317.5	234.0	27.0	114.0	234.0	6	91.0
104 1/2	41971	598	3200	207	346.1	262.0	27.0	127.0	263.0	8	123.0
105	56560	806	2900	224	388.9	298.0	38.0	145.0	293.0	8	182.0
105 1/2	73985	1054	2650	250	425.5	316.0	38.0	153.0	325.0	8	279.0
106	90345	1287	2450	278	457.2	336.0	25.0	188.0	356.0	8	333.0
107	135160	1926	2150	320	527.0	396.0	28.5	187.5	406.4	12	530.0

ACOPLAMENTOS DE ENGENAGENS **POR** Rígido
ACOPLAMIENTOS DE ENGRANAJES **ESP** Rígido
GEAR COUPLINGS **ENG** Rigid

TARR

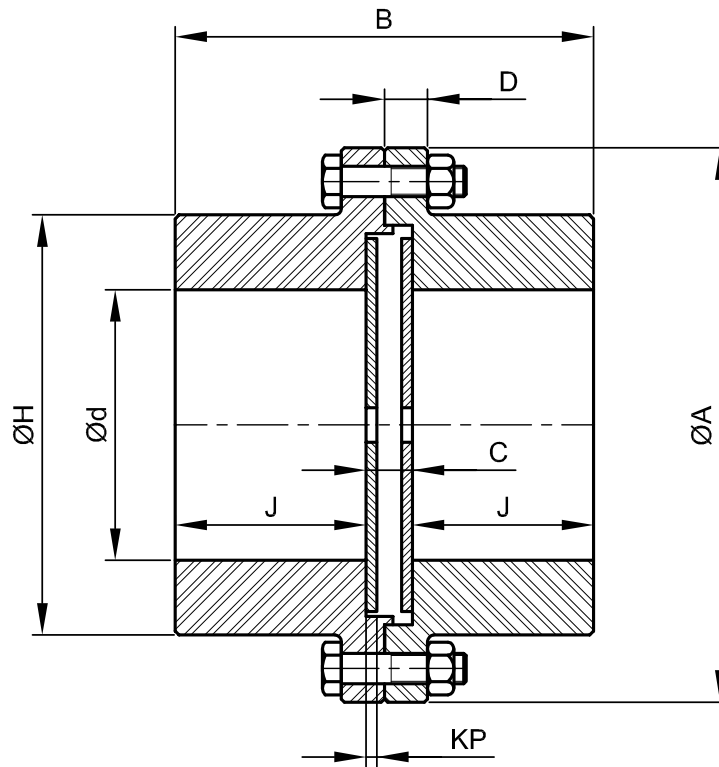

Tamaño Tamaño Size	Torque Nm	rpm max	ø d max	ØA	B	D	J	H	KP	C gap	Peso Weight Kg
101	1275	6000	48	115.9	149.4	14.2	60.5	78.0	6.4	28.4	5.5
101 ^{1/4}	1900	6000	50	130.0	152.4	16.0	62.0	83.0	6.4	28.4	7.8
101 ^{1/2}	2570	5500	58	152.4	168.6	19.0	63.5	100.0	6.4	41.6	11.2
102	4400	5000	72	177.8	183.2	19.0	72.4	124.0	6.4	38.4	17.6
102 ^{1/2}	7825	4400	89	212.8	222.8	22.0	92.2	149.0	6.4	38.4	30.6
103	1300	4000	105	239.7	236.4	22.0	99.0	174.0	6.4	38.4	43.0
103 ^{1/2}	20000	3500	136	279.4	270.0	29.0	114.3	200.0	6.4	41.4	63.0
104	29800	3000	152	317.5	301.4	29.0	130.0	235.0	6.4	41.4	94.0
104 ^{1/2}	40000	2700	174	346.1	339.4	29.0	149.0	264.0	6.4	41.4	127.0
105	57500	2500	190	388.9	377.4	38.0	168.0	293.0	6.4	41.4	167.0
105 ^{1/2}	75800	2200	216	425.5	415.8	38.0	187.2	325.0	6.4	41.4	222.0
106	99000	2100	235	457.2	453.8	25.0	206.2	356.0	6.4	41.4	271.0
107	134000	2000	266	527.0	531.2	29.0	229.0	406.0	12.7	73.2	406.0
8	195000	1900	311	591.0	637.2	33.0	282.0	466.0	12.7	73.2	631.0
9	270000	1800	343	660.0	673.2	38.0	300.0	518.0	12.7	73.2	838.0
10	370000	1550	378	711.0	701.2	38.0	314.0	566.0	12.7	73.2	1044.0
11	510000	1400	412	775.0	761.7	41.4	333.5	620.0	19.0	95.3	1308.0
12	650000	1300	444	838.0	800.5	41.4	352.6	676.0	19.0	93.3	1670.0

