

**Completely Enclosed Continuous Operation
No “Down-Time” Lubrication Maintenance
CEUM-Series “M” CECON® Clutches**

Service & Installation Instructions

**P-1346-3-MC
BULLETIN C-302M**



▲WARNING Failure to follow these instructions may result in product damage, equipment damage, and serious or fatal injury to personnel.

Installation, Lubrication, and Maintenance

General

Marland CECON Clutches are designed for continuous operation 24 hours a day for a whole year or longer, if required. Since such continuous operation is directly influenced by the care observed in installation, lubrication, and maintenance, it is important that the following recommendations be used as the basis for proper care of CECON Clutch units.

As soon as the unit has been received, examine it carefully for damage in transit and report any breakage discovered to the transit company at once.

All tags and bulletins attached to the unit should be carefully read before placing the unit in operation and then filed for future reference.

▲CAUTION Care must be taken not to place the unit in operation until it has been filled with oil of proper specification to the static oil level. See Step "Starting".

The various component parts referred to in this bulletin may be readily identified on CEUM Diagram and Parts List.

Electrical Grounding

Tapped holes are provided for electrical grounding of the unit. Contact Marland for the optional electrical grounding kit.

Storage

CECON Clutch units have been coated internally with a preservative oil to protect the internal working parts from corrosion during shipment and a preparation period of not more than one week after arrival at the site before the unit is placed in regular operation. It is not necessary to flush out the preservative oil from the CECON housing, as this oil will be diluted by introduction of the regular oil supply.

The shaft ends and couplings have also been coated with a preservative oil. Do not wash this protective coating from shaft ends or couplings.

If the unit is to be stored for a period of time, immediately fill with the proper quantity and grade of oil as shown on the nameplate attached to the housing. To fill, remove the 3/4" square head pipe plug on inspection cover (Part No. 7). Pour the quantity required into this opening. Replace pipe plug. To keep the unit airtight, do not install static oil level gauge or breather-filter. Be sure to rotate shafts at least once every two weeks.

If the unit is to be immediately installed and operated upon its arrival at the site, proceed with the installation as per the instructions that follow.

Foundations

Care should be taken in the selection of flexible foundations such as light steel or timber structures as they may produce damaging effects.

A rigid foundation such as a reinforced concrete bed or substantial steel structure is recommended. The top of the foundation should be flat to prevent housing distortion.

If the CECON unit is to be mounted on a concrete foundation, a steel base plate containing the foot mounting bolts should first be anchored to the foundation.

Installation

Two eyebolts are provided on the clutch housing. These are to be used when moving, lifting, and lowering the CECON unit into position.

▲CAUTION CECON units should never be handled by placing slings or chains around the shaft extensions.

A. Direction of Rotation

The CECON unit output shaft (Part No. 26) must be arranged for freewheeling rotation. The nameplate attached to the clutch housing end plate identifies the output shaft. This shaft is to be connected to the shaft of the driven equipment.

The CECON unit input shaft (Part No. 12) is also identified by nameplate on the clutch housing. The input shaft is at the same end of the CECON unit as the running oil level gauge (Part No. 8). This shaft is to be connected to the shaft of the driving equipment.

As a further precaution before proceeding with the assembly, check the direction of freewheeling rotation by holding the CECON input shaft (Part No.

12) stationary while trying to rotate the output shaft (Part No. 26) first in one direction and then in the opposite.

▲CAUTION Be sure the free rotation is in the desired direction.

B. Drain Valve and Static Oil Gauge

Insert drain valve and static oil level sight gauge before CECON unit is lowered into position. Drain valve (Part No. 23) and static oil level sight gauge (Part No. 40) may be located on the same or opposite sides of the housing. Use the pipe plug that was removed from housing as safety plug in end of the drain valve.

C. Alignment

We recommend that the coupling hubs and sleeves for the CECON unit shafts be sent to our factory for mounting.

Accurate alignment of the CECON unit shafts with the shafts of the connected equipment is most important and should be done in accordance with the coupling manufacturer's instructions. Misalignment may develop unnecessary overloads and stresses in shafts and bearings, and can be responsible for failure of the equipment. If Marland Clutch has furnished the couplings, see Coupling Data Sheet enclosed with this bulletin.

CECON Clutch unit shafts should be connected to the driver and driven equipment shafts through suitable sizes of double-engagement, self-aligning, gear-type flexible couplings. Do not use couplings of pin, flexible spring, or single-engagement types without the approval of Marland Clutch.

Never use heavy blows on CECON unit shafts when aligning, mounting hubs, fitting keys, etc. Evidence of damage caused by disregard of these instructions is readily traceable, and Marland Clutch will not be held responsible for the failure of the affected part or parts.

After the CECON has been lowered in place, it is desirable to use metal shims to obtain proper alignment of the CECON unit shafts with the shafts of the driver and driven equipment. Locate housing axially to provide shaft gaps per coupling manufacturer or as shown on the certified drawing. Use shims under feet of housing, preferably U-shaped, to fit around mounting bolts evenly. Tapped through holes for Jacking Screws are provided to assist in the installation of the metal shims.

Failure to properly shim the CECON unit housing feet may cause the housing to distort when the mounting bolts are tightened.

For inclined applications, refer to the certified drawing for the approved inclined longitudinal mounting axis. The transverse axis must be placed in a horizontal position and checked with a spirit level indicator.

It is important that the alignment of the CECON unit shafts with the shafts of the driver and driven equipment be rechecked after the final tightening of the mounting bolts, and before the coupling sleeves are bolted together.

After the installation has been properly aligned, dowel the CECON unit in place by using two dowels, locating them on the same side of the housing. Doweling will preserve the original alignment and proper shaft relationship should it become necessary to remove and reinstall the CECON unit, thus providing every possible precaution against wrong reassembly.

Starting

A. Fill with Oil

CECON Clutch units are shipped without oil.

Before placing in operation, the unit must be filled with oil of the grade specified on the nameplate, to the level indicated on the static oil level sight gauge (Part No. 40). The approximate oil capacity for filling to the static oil level is shown on the certified drawing and nameplate.

▲CAUTION Oil containing high lubricity or EP additives must not be used in clutch units. Never use grease for internal lubrication of the clutch. The use of improper lubricants could cause a malfunction resulting in equipment damage.

DEXRON III Automatic Transmission Fluid is recommended for year-around lubrication in Marland CECON Clutches. Any changes in lubricant specifications will be noted on the nameplate.

To fill the unit with oil, thoroughly clean around the 3/4" square pipe on the inspection cover to prevent foreign material from entering the housing. Remove the 3/4" square head pipe plug. Fill unit with oil through this opening, allow sufficient time for the oil to seek its natural static level in the housing as indicated by the STATIC oil level sight gauge. Insert the breather-filter (Part No. 36), using the elbow fittings that are furnished, in place of the pipe plug.

B. Lubricate Couplings

Lubricate the couplings connecting CECON input and output shafts to the driver and driven shafts in accordance with the coupling manufacturer's instructions. If Marland Clutch has furnished the couplings, see Coupling Data Sheet enclosed with this bulletin.

C. Initial Startup

During the initial starting operation, check to determine if there is any evidence of localized heating; if the lubrication appears satisfactory; and whether there is any vibration present due to loose foundation bolts or misalignment of shafts. If any correction is necessary, it should be made before placing the CECON unit into continuous operation.

Note: Oil level may take up to ten minutes at the maximum intended speed.

Lubrication Maintenance

A. Oil Level Gauges

CECON units are provided with 2 oil level sight gauges. One is located at the end of the clutch housing to indicate the minimum oil level to be maintained when the unit is in continuous operation, or has been operating for at least 10 minutes at the maximum intended speed. The other oil level gauge is located at the bottom of the side of the clutch housing and indicates only the static oil level.

B. Running Oil Level

During operation the CECON unit oil level should be maintained at or above the minimum running level as marked for the oil level sight gauge located at the end of the clutch housing.

When the oil level is below the minimum running level, sufficient oil should be added to bring the level up to the indicated minimum running level. It is not necessary to stop the CECON unit when adding oil.

Important: Running oil level may drop below the minimum indicated during slow speeds of the input shaft, such as in starter drives, creep drives, etc. The static level indicated on the side of the housing is sufficient for proper lubrication.

Improper maintenance methods are often responsible for dirt and foreign matter getting into the oil, and subsequently, into the CECON housing. Keep oil supply and containers, pumps, or funnels used for filling, clean and free from contamination.

C. Sampling of Oil

To obtain long, trouble-free service from your CECON unit, it is necessary that the lubricating oil within the housing be clean and free from sludge

at all times. To be assured of this, make frequent inspection of the condition of the oil by sampling a sufficient quantity through the sampling or drain valve (Part No. 23). Such sampling may be done while the unit is running and does not require an interruption of operations.

Visual observation of the running oil level gauge will provide a further check on oil purity.

The frequency with which the CECON unit lubricating oil is sampled or replaced is an important consideration and can only be determined by individual experience. However, it is considered desirable to sample the lubrication several times at weekly intervals after the unit has been placed in operation. The results of such samplings will dictate the frequency for future samplings, which could possibly extend to one month intervals, but in any event should not exceed three months.

Whenever sampling of the oil indicates contamination by moisture or foreign matter, such impurities may be withdrawn from the housing through the drain valve. If the unit is in operation, do not withdraw more than 1 quart at a time. The amount withdrawn should be immediately replaced with fresh specified oil. Replacement oil may be added through the initial oil fill hole.

D. Changing of Oil

Timing of oil change is determined by the results of oil sampling. Unless results of oil sampling suggest otherwise, the oil within the clutch should be completely changed once a year for continuous duty applications.

E. Breather-Filter

The breather-filter should be cleaned at regular intervals. The frequency of such servicing depends upon the condition of the filter element when examined and cleaned after a short period of operation.

F. Couplings

Follow coupling manufacturer's recommendations regarding lubrication and maintenance of the couplings.

Service

Field disassembly and repair of CECON Clutch is not recommended. Should problems occur, contact Marland Clutch directly.

▲CAUTION Rotating equipment is potentially dangerous and could cause injury or damage if not properly protected. Follow applicable codes and regulations.

CEUM Diagram

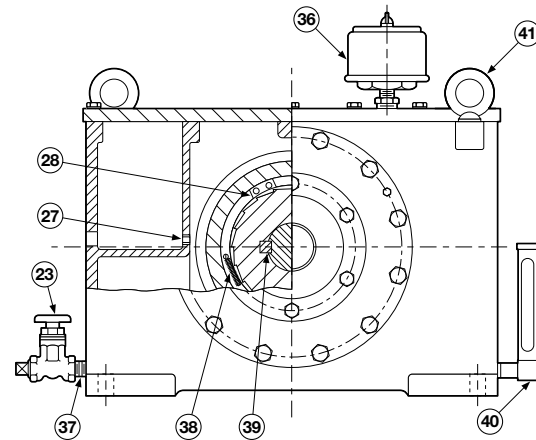
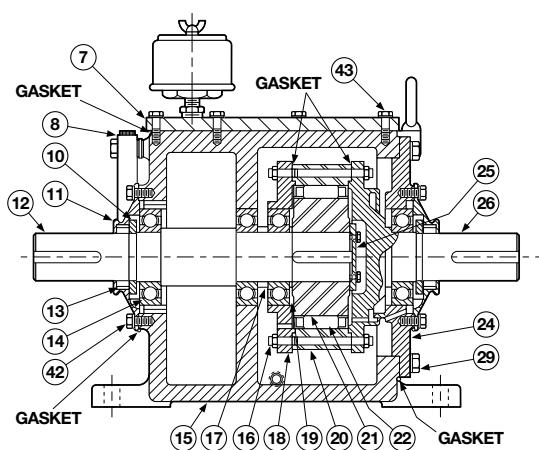

Part #	Description
7	Housing Cover & Gasket
8	Running Oil Level Gauge
10	Oil Slinger
11	Shaft Seal Cover & Gasket
12	Input Shaft
13	Oil Seal
14	Ball Bearing
15	Clutch Housing
16	Bolts & Locknut for 20
17	Bearing Spacer
18	Clutch Coverplate
19	Cam Spacer
20	Outer Race & Gasket
21	Cam
22	Clutch Roller Assembly

Part #	Description
23	Drain Valve
24	Housing End Plate & Gasket
25	Cam Retainer & Fasteners
26	Flanged Output Shaft
27	Oil Flow Plug
28	Clutch Stop Lug
29	Screws & Lockwashers for 24
36	Breather-Filter
37	Pipe Nipple
38	Clutch Spring
39	Clutch Cam Key
40	Static Oil Level Gauge
41	Eye Bolt
42	Screws & Lockwashers for 11
43	Screws & Lockwashers for 7

Warranty

Marland Clutch warrants that it will repair or replace (whichever it deems advisable) any product manufactured and sold by it which proves to be defective in material or workmanship within a period of three (3) years from date of shipment. This warranty extends only to the original purchaser and is not transferable or assignable without Marland Clutch's prior consent.

This warranty covers normal use and does not cover damage or defect which results from alteration, accident, neglect, or improper installation, operation, or maintenance.

Marland Clutch's obligation under this warranty is limited to the repair or replacement of the defective product and in no event shall Marland Clutch be liable for consequential, indirect or incidental damages of any kind incurred by reasons of manufacture, sale or use of any defective product. Marland Clutch either assumes nor authorizes any other person to give any other warranty or to assume any other obligation or liability on its behalf.



www.marland.com

23601 Hoover Rd.
Warren, MI. 48089
800-216-3515