

One-Way CEBMAG® Backstops For Kiln Emergency Drive Protection



Table of Contents

Operating Details 2
Design Features and Size Selection 3
Kiln Emergency Drive Arrangements 4
Kiln Emergency Drive Alternate Arrangements 5
Marland One-Way CEBMAG Backstops 6
Dimensions and Data..... 7

The Marland One-Way CEBMAG Backstop

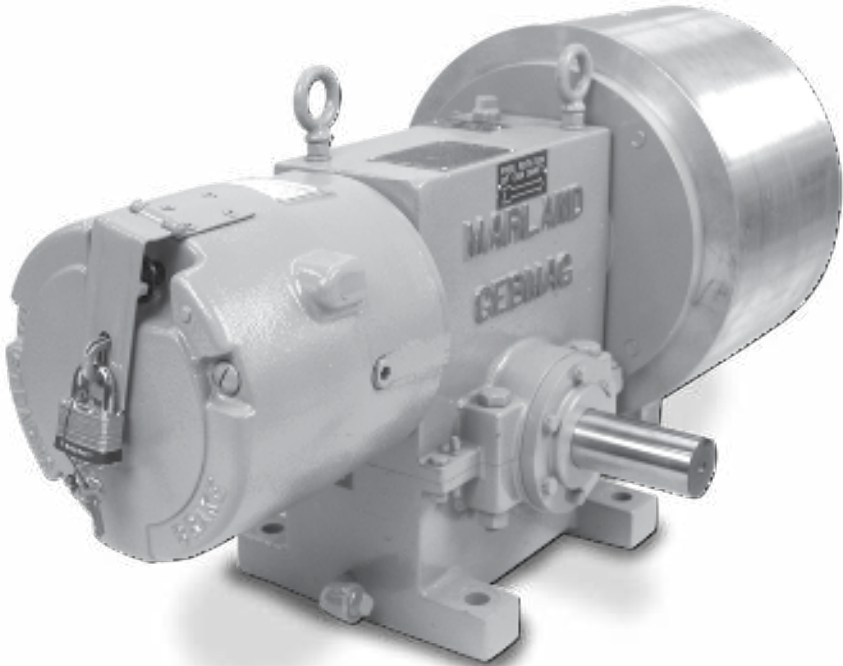

Cover:
Marland One-Way CECON clutch and CEBMAG Backstop on Modern cement kiln provide for emergency drive rotation in case of main power shutdown. Drive arrangement as per Alternative D, page 6.

The Need For CEBMAG

Backstops

For some time, the trend in the cement and other pyro-processing industries has been toward larger and more efficient kilns. Since these kilns operate 24 hours per day, month after month, it has been important to conserve power and avoid down time as much as possible.

The high degree of efficiency in the mechanical power transmission that has evolved also means that the kiln can roll back due to the large off-center mass of material in the kiln when power failure occurs or at any time the main drive is shut down. Uncontrolled rollback carries the danger of centrifugal explosion of the main drive components since they may be oversped to many times the normal forward speed.

Another consideration to be made during main drive shutdown is the prevention of kiln distortion due to the high temperatures. An emergency drive can be utilized to provide forward rotation at a reduced speed, both to prevent distortion and also to empty the contents of the kiln before it becomes impacted to the lining.

Marland CECON clutches and CEBMAG backstops provide automatic, remote emergency operation in case of main electric power failure. Their use provides for controlled reversal of the kiln and automatic changeover to emergency drive for forward rotation at reduced speed.

The first Marland clutches installed on a cement kiln went into operation over 25 years ago. Since that time, many of the largest kilns in this country and throughout the world have been provided with CECON and CEBMAG units.

For more detailed information on CECON clutches refer to CECON catalog P-1471-MC.

General

The Marland One-Way CEBMAG Backstop is primarily designed for application in kiln emergency drive systems in conjunction with the Marland CECON Clutch. The requirements of such a system are:

- A. Provide automatic means for controlling reversal of kiln, during planned or emergency shutdown. The unit must not only automatically hold the kiln from **free** reversal, as any backstop can do, but also, it must provide for **controlled** kiln reversal when the backstop is released. During **controlled** reversal, full-time automatic protection from over-speeding of the main and emergency drive systems is necessary in order not to run the risks of personal injury or damage to equipment through centrifugal explosions of motors, engine fly-wheels, or couplings. This over-speed is caused by the rollback from almost free response to gravity of the large off-center mass of material in the kiln, and may be many times the normal forward load-carrying speed.
- B. Must be able to operate automatically under extremely wet, dusty abrasive or other adverse atmospheric conditions in unprotected outdoor installations.

To the best of our knowledge, the CEBMAG unit is unique in that it is the only unit of its type to have in-built in one package, an automatic freewheeling one-way clutch on the main emergency drive shaft (cam shaft) and two brakes (one electromagnetic and one centrifugal) mounted on the secondary shaft (worm shaft) that are automatically engaged when the main (cam) shaft tries to reverse

direction of rotation. If these brakes were placed elsewhere in the emergency drive system, rather than on the secondary (worm) shaft, one or both of the brakes would be constantly engaged regardless of direction of kiln rotation.

The electro-magnetic brake **HOLDS** the reverse load caused by the kiln, and is of the disc type, with spring set and electrical release. This permits central station control. An external manual release is also furnished to allow for on-job-site release. The automatic acting centrifugal brake **retards** the reverse load caused by the kiln when the electromagnetic brake is released, and allows **controlled** reversal of the kiln in order to protect from over-speeding of the main and emergency drive systems.

Design Features and Size Selection

Design Features

- A. The freewheeling clutch is contained in a completely dust and oil tight horizontally split housing, with provisions for supporting the freewheeling clutch, cam shaft, and secondary (worm) shaft. Liberal housing area is provided to insure adequate cooling of the lubricant.
- B. The freewheeling clutch elements are of the fully phased roller and cam type, consisting of cylindrical rollers contained in a precision machined cage, and actuated to engage all rollers simultaneously between the outer race and the inclined precision ground planes of the cam shaft.
- C. A precision machined, reversible high helix angle worm and gear set is used to transmit the load during kiln reversal **through** the engaged automatic one way clutch to the brakes mounted on the secondary (worm) shaft.
- D. Shafting is provided with adequate sealing to guard against loss of lubricant or entry of foreign matter when shafts are not always horizontal as on some kiln installations.
- E. An oil level indicator, which is clearly visible and can be observed whether the unit is in operation or idle, is provided to show correct level to be maintained in the reservoir of the enclosed housing. The **static oil level** provides a large volume of oil many times the capacity of an ordinary freewheeling clutch.
- F. The oil slingers on the cam shaft provide continuous self-lubrication through centrifugal displacement of the oil in the reservoir during freewheeling or driving rotation to insure abundant lubrication of all working parts instantly upon starting.
- G. A drain valve is provided for easy sampling of the lubricant to help detect the presence of any foreign matter and to permit withdrawal of any such impurities from the reservoir.
- H. A breather-filter fastened into the oil fill cap on the top of the housing is provided to prevent entry of abrasive dust or moisture into the unit during a change of atmospheric temperature and during a change in operating temperature of the atmosphere in the unit.
- I. The electromagnetic brake **holds** the reverse load caused by the kiln during planned or emergency shutdown. This brake is of the disc type with spring set and electrical release. This permits central station control. An external manual release is also furnished to allow for on-job-site release.
- J. The centrifugal brake automatically engages the brake drum at a pre-determined speed through the centrifugal action of the individual brake shoe segments and against their retaining springs, caused by the kiln reversal when the electromagnetic brake is released. This action limits the main and emergency drive systems to a safe **controlled** reversal speed.
- K. A brake drum of liberal proportions is provided so as to adequately serve as a heat sink when the centrifugal brake engages.
- B. Auxiliary Drive:
 - Number of drives
 - HP of each drive
 - RPM of each drive
 - Type: Engine or Electric Motor
- C. Auxiliary Reducer Ratio
- D. Main Reducer Ratio
- E. Girth Gear and Pinion Ratio
- F. Amount and Direction of Kiln Slope With Respect To Drive Arrangement
- G. Voltage To Be Supplied To CEBMAG Electric Brake
- H. Micrometered Shaft Diameters, If Couplings Are Supplied By Marland:
 - 1. Auxiliary drive shaft
 - 2. Auxiliary reducer high-speed shaft
 - 3. Auxiliary reducer low-speed shaft
 - 4. Main reducer high-speed shaft
- I. Direction Of Rotation Of CEBMAG Backstop And CEBCON Clutch Viewed Facing Input Shafts Of These Units.

Special Requirements

In nearly 50 years as the recognized leader in the design and manufacture of freewheeling clutches, the Marland engineering staff has been given many unusual and difficult requirements for clutches and backstops. This has resulted in special designs to meet those exacting requirements. If your needs cannot be filled by a standard item, give us the engineering details. It may be that we already have a solution to your problems, and if not, we'll go to work and find one.

Size Selection Data

Selection of the CEBCON Clutch and CEBMAG Backstop is generally made by our factory since the auxiliary and main drive arrangements of a typical installation contain variable conditions and special considerations. The information necessary to properly selection these units is as follows:

- A. Main Motors:
 - Number of motors
 - HP of each motor
 - RPM of each motor

Kiln Emergency Drive Arrangements

CECON clutch and CEBMAG backstop on this modern cement kiln emergency stand-by drive is completely automatic in operation for remote, central station control. CEBMAG backstop prevents uncontrolled reversed runback of kiln. Drive arrangement as per Alternative A.

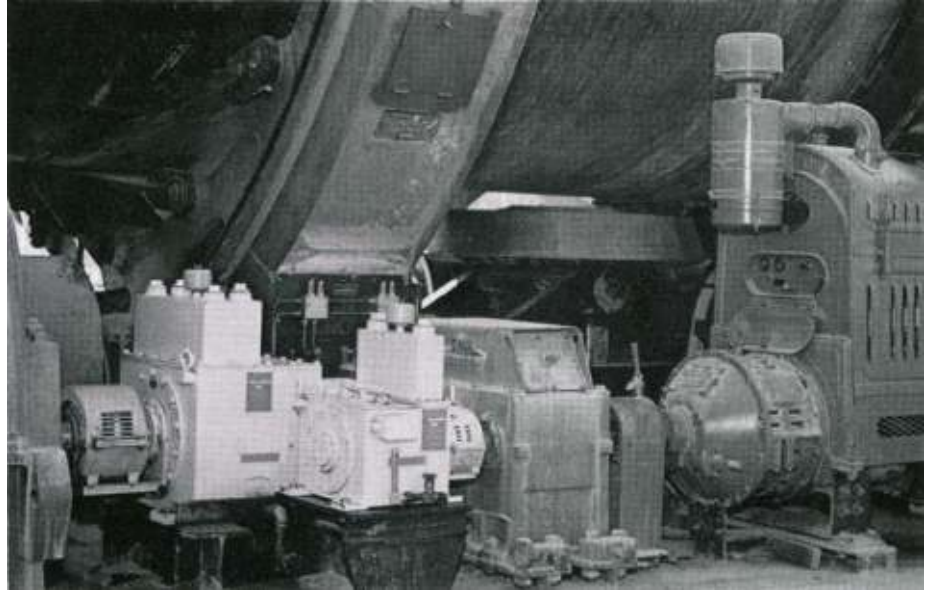

Alternative A

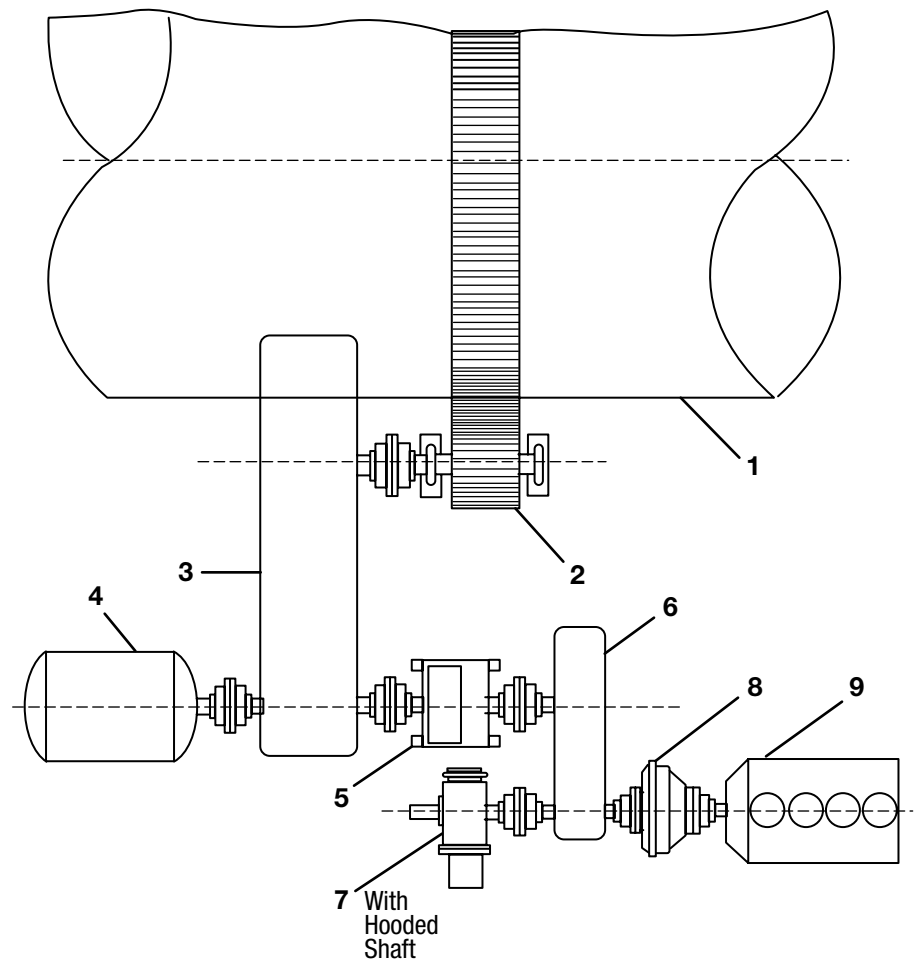

Kiln Emergency Drive Alternative Arrangements

Alternative B

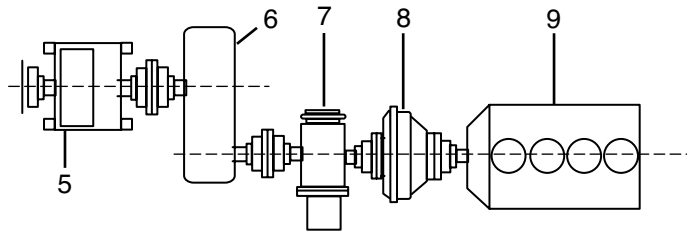

Alternative C

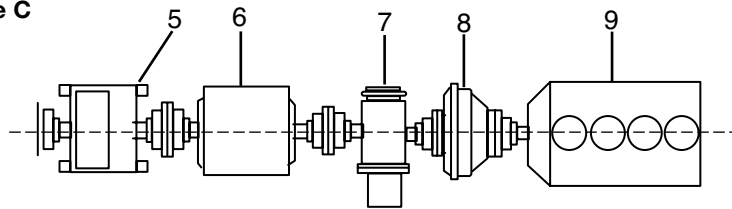

Alternative D

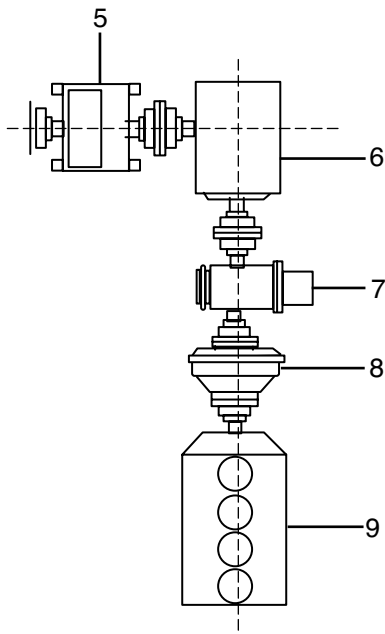

Alternative E

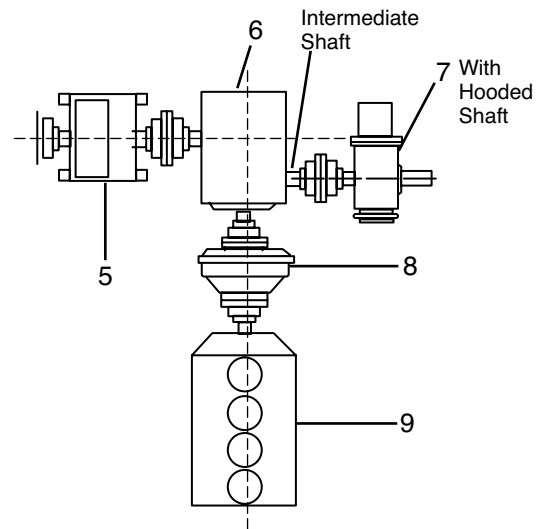

Part	Description
1	Kiln
2	Kiln Drive Pinion
3	Main Drive Speed Reducer
4	Main Drive Motor
5	Marland One Way CEBMAG Backstop (A) permits emergency drive to remain stationary or to run while main drive is in operation (B) engages emergency drive automatically to main drive to rotate kiln when drive is off (C) engages automatically to rotate emergency drive when kiln reverses.
6	Emergency Drive Speed Reducer
7	Marland One Way CEBMAG Backstop (A) holds kiln from reversing when either main drive or emergency drive is shutdown (B) controls reversal of kiln when brake is released (C) permits emergency drive to rotate kiln
8	Fluid or Centrifugal Clutch with Gear Type Coupling
9	Emergency Drive Engine or Electric Motor

Marland One-Way CEBMAG Backstops

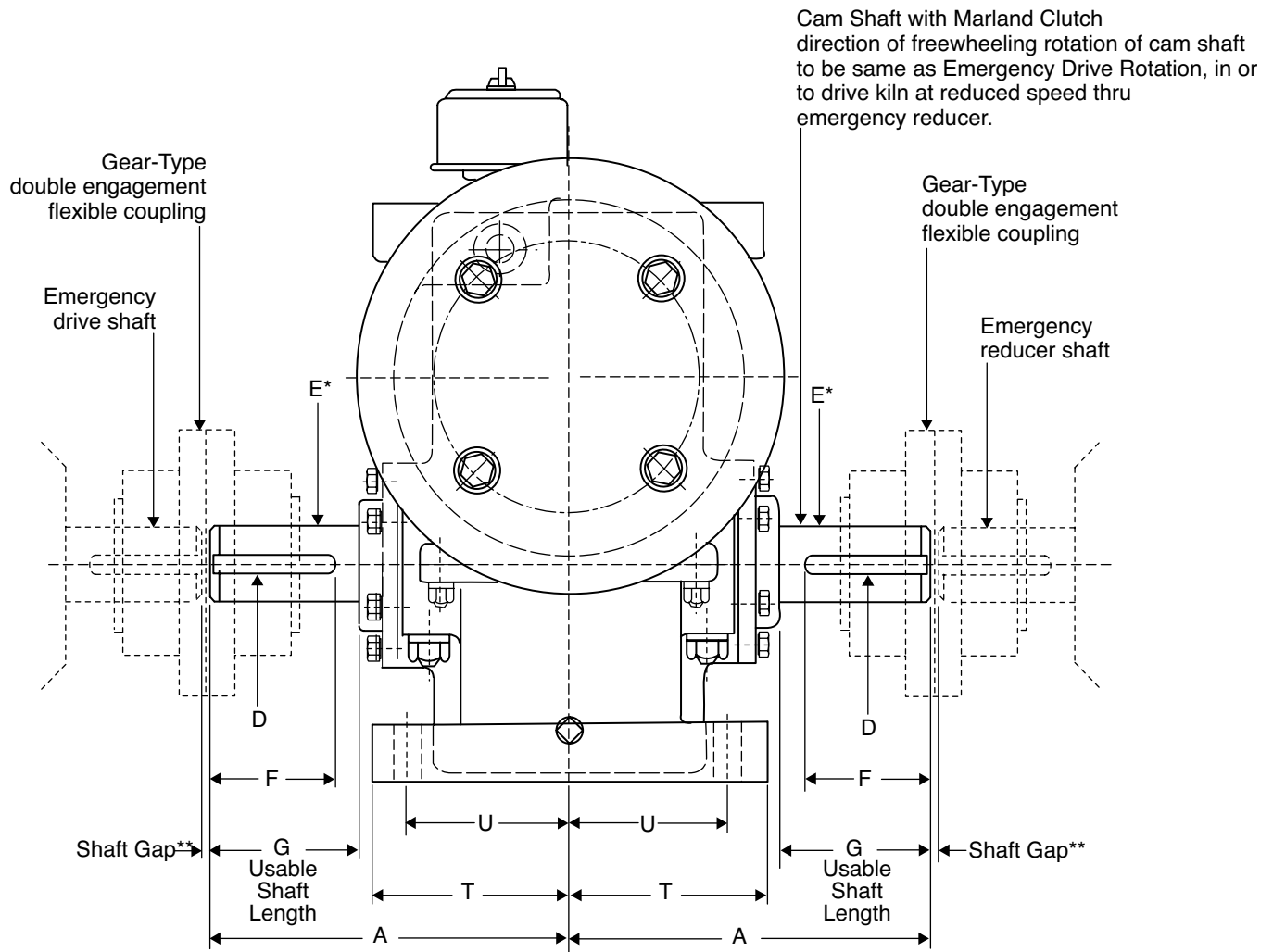

CEBMAG Backstop Size	Rated Torque Capacity lb.ft.	Oil Capacity Pints	Shipping Weight lbs.
5C-W	500	7	410
1M-W	1,000	7	530
2M-W	2,000	10	690
4M-W	4,000	13	920

* Shaft Dia. + .0000/- .0010
Coupling Bore -.0010/- .0015

** Shaft gap per coupling Manufacturer or customer specification.

Consult applicable Local and National Safety Codes for proper guarding of rotating shafts and couplings.

Dimensions and Data

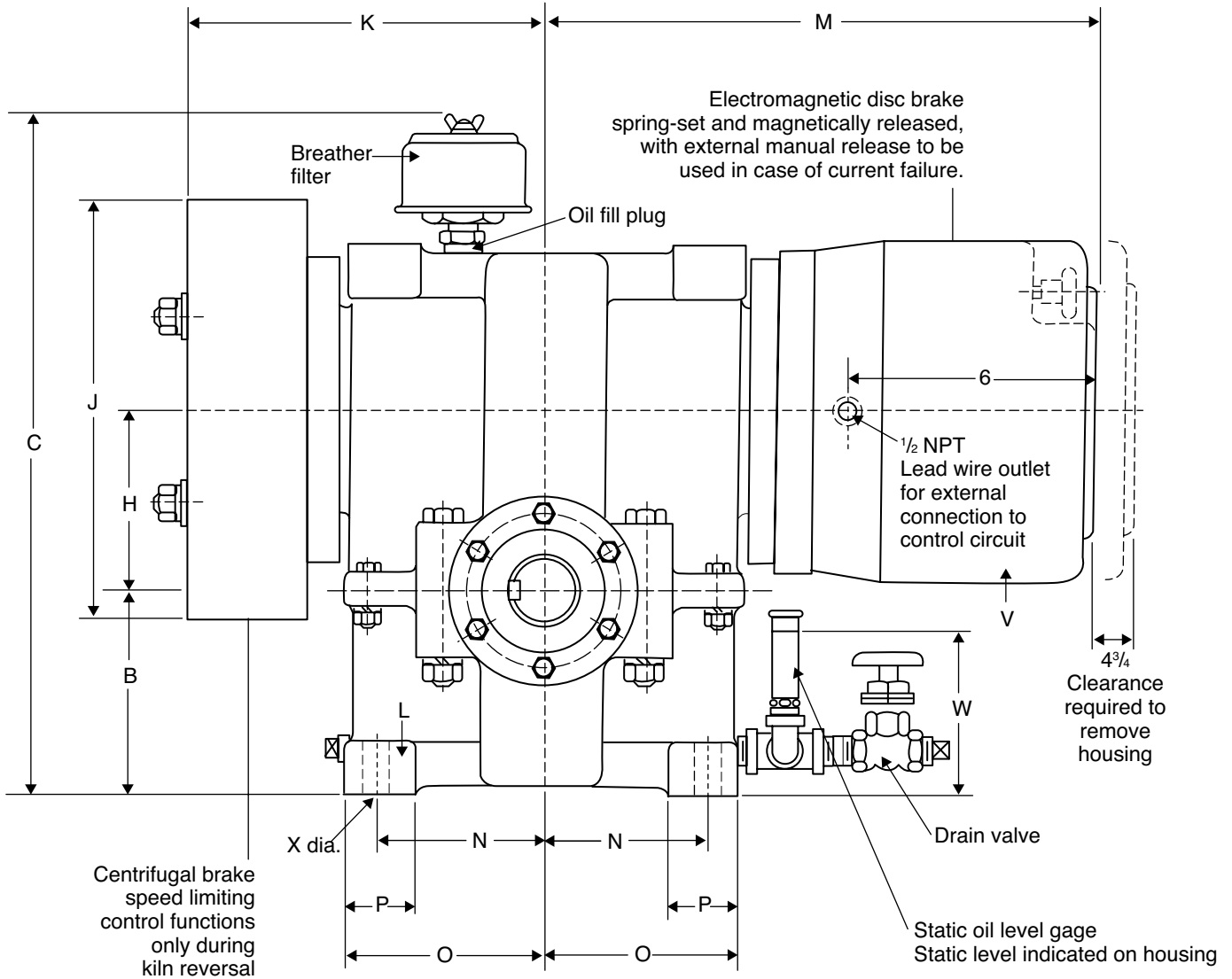

CEBMAG Backstop Size	Dimensions in Inches (For Reference Only)																			
	A	B	C	D	E	F	G	H	J*	K*	L	M*	N	O	P	T	U	V*	W	X
5C-W	9 1/4	5 1/4	19 1/4	1/2 x 1/2	2	3 3/4	4 1/4	5	11 1/4	10 1/4	1 1/4	14 3/4	4 1/4	5 1/4	2	5 3/4	4 3/4	9 1/4	5 1/4	1 1/4
1M-W	9 1/4	5 1/4	19 1/4	1/2 x 1/2	2	3 3/4	4 1/4	5	13	10 1/4	1 1/4	14 3/4	4 1/4	5 1/4	2	5 3/4	4 3/4	9 1/4	5 1/4	1 1/4
2M-W	10 1/4	6 1/4	21	5/8 x 5/8	2 1/2	3 3/4	4 1/4	6	15	11 1/4	1 1/4	19 1/4	5 1/4	6 1/4	3	6 1/4	4 3/4	15 1/4	5 1/4	1 1/4
4M-W	11 1/4	7 1/4	24	3/4 x 3/4	2 3/4	5 1/4	5 1/4	7	17	12 1/4	1 1/4	21 1/4	6	7 1/4	3	6 1/4	5	15 1/4	6 1/4	1 1/4

*These Dimensions Subject To Change Depending Upon Electrical and Other Variables.

The Power Of One, The Strength Of Many.

OTHER PRODUCT SOLUTIONS FROM
ALTRA INDUSTRIAL MOTION

WWW.ALTRAMOTION.COM

Our comprehensive product offerings include various types of clutches and brakes, overrunning clutches, engineered bearing assemblies, gearing and gear motors along with linear products, belted drives, couplings and limit switches. With thousands of product solutions available, Altra provides true single source convenience while meeting specific customer requirements. Many major OEMs and end users prefer Altra products as their No. 1 choice for performance and reliability.



ELECTRIC CLUTCHES AND BRAKES

Inertia Dynamics
Matrix
Stromag
Warner Electric



HEAVY DUTY CLUTCHES AND BRAKES

Industrial Clutch
Stromag
Svendborg Brakes
Twiflex
Wichita Clutch



OVERRUNNING CLUTCHES

Formsprag Clutch
Marland Clutch
Stieber



ENGINEERED COUPLINGS AND UNIVERSAL JOINTS

Ameridrives
Bibby Turboflex
Guardian Couplings
Huco
Lamiflex Couplings
Stromag
TB Wood's



GEAR DRIVES

Bauer Gear Motor
Boston Gear
Delroyd Worm Gear
Nuttall Gear



GEAR MOTORS

Bauer Gear Motor



POWER TRANSMISSION COMPONENTS

LINEAR ACTUATORS AND CONTROLS

Warner Linear



ENGINEERED BEARING ASSEMBLIES

Kilian



AIR MOTORS

Huco



BELTED DRIVES AND SHEAVES

TB Wood's



GEARED CAM LIMIT SWITCHES

Stromag

Marland Clutch Facilities

North America

USA

23601 Hoover Road
Warren, MI 48089 - USA
1-800-216-3515

*Roller Ramp and Sprag Type
Overrunning Clutches
and Backstops*

Europe

Germany

Hatschekstraße 36
69126 Heidelberg - Germany
+49 (0) 6221-30470

*Overrunning Clutches
and Holdbacks*

Asia Pacific

Australia

+61 2 9894 0133

China

+86 21 5169-9255

Hong Kong

+852 2615 9313

Singapore

+65 6487 4464

Taiwan

+886 2 2577 8156

Thailand

+66 2322 5527

The Brands of Altra Industrial Motion

Couplings

Ameridrives
www.ameridrives.com

Bibby Turboflex
www.bibbyturboflex.com

Guardian Couplings
www.guardiancouplings.com

Huco
www.huco.com

Lamiflex Couplings
www.lamiflexcouplings.com

Stromag
www.stromag.com

TB Wood's
www.tbwoods.com

G geared Cam Limit Switches

Stromag
www.stromag.com

Electric Clutches & Brakes

Inertia Dynamics
www.idicb.com

Matrix
www.matrix-international.com

Stromag
www.stromag.com

Warner Electric
www.warnerelectric.com

Linear Products

Warner Linear
www.warnerlinear.com

Engineered Bearing Assemblies

Kilian
www.kilianbearings.com

Heavy Duty Clutches & Brakes

Industrial Clutch
www.indclutch.com

Twiflex
www.twiflex.com

Stromag
www.stromag.com

Svendborg Brakes
www.svendborg-brakes.com

Wichita Clutch
www.wichitaclutch.com

Belted Drives

TB Wood's
www.tbwoods.com

Gearing

Bauer Gear Motor
www.bauergears.com

Boston Gear
www.bostongear.com

Delroyd Worm Gear
www.delroyd.com

Nuttall Gear
www.nuttallgear.com

Overrunning Clutches

Formsprag Clutch
www.formsprag.com

Marland Clutch
www.marland.com

Stieber
www.stieberclutch.com

Neither the accuracy nor completeness of the information contained in this publication is guaranteed by the company and may be subject to change in its sole discretion. The operating and performance characteristics of these products may vary depending on the application, installation, operating conditions and environmental factors. The company's terms and conditions of sale can be viewed at <http://www.altramotion.com/terms-and-conditions/sales-terms-and-conditions>. These terms and conditions apply to any person who may buy, acquire or use a product referred to herein, including any person who buys from a licensed distributor of these branded products.

©2018 by Marland Clutch LLC. All rights reserved. All trademarks in this publication are the sole and exclusive property of Marland Clutch LLC or one of its affiliated companies.