

CECON[®] Clutches

Completely Enclosed for Continuous Operation



The Company

Marland

Since 1931, Marland has been producing backstops, clutches and clutch couplings. Marland products are based on a one-way clutch design, utilizing the principle of cylindrical rollers on inclined cam planes.

Marland Clutch also provides a line of proven sprag type freewheel clutches. Marland utilizes the knowledge of its sister divisions, Stieber® of Germany and Formsprag® of the United States, to manufacture world class high performance sprag clutches in the United States.

Marland Products

The Marland principle of rollers on inclined cam planes has proven its dependability for over 70 years in worldwide installations ranging from food processing plants to equipment used in steel mills and heavy mining industries. Proving the inherently long-life Marland design, the first two Marland clutch units installed in February, 1931, operated continuously for 31 years without repairs or replacements of any kind until the system became obsolete in 1962. Cam, rollers and outer race inspection showed them ready for additional years of service.

The Need for CECON Clutches

Marland CECON Clutches are designed for applications where one or more of the following conditions exists.

1. Shaft speeds exceeds the permissible maximum for standard clutches, clutch couplings, or backstops.
2. Uninterrupted, continuous operation is required.
3. Operation under extremely wet, dusty, abrasive, or other adverse atmospheric conditions; or on unprotected outdoor applications; or subject to high ambient temperatures.
4. Shaft axis is not horizontal, as on cement kiln drives.
5. Lubrication maintenance must be provided on a no "down-time" basis.

Illustration 1

Aluminum alloy cage with precision machined roller pockets results in controlled spacing and load sharing.

SAE 52100 Alloy Steel Rollers



Energizing springs insure positive engagement, even for rapid indexing rates up to 240 stoke per minute.

Cam ground with same precisely phased cam lobe spacing as used for the cage.

The quality management system that supports the Marland Products has been certified to ISO 9001:2008



CECON Clutches consist of a completely enclosed housing with provisions for supporting a Marland freewheeling clutch between two shafts, each of which is separately supported. The input shaft is connected to the cam and the output shaft is connected to the outer race. The CECON shafts are then connected to driving and driven equipment through double engagement, self-aligning flexible couplings.

During freewheeling, the outer race, as shown by the arrow in Illustration 2, is free to rotate with the output shaft. The cam and roller assembly connected to the input shaft remain stationary, or rotate at a speed slower than the output shaft. An oil film wedges and separates the rollers from the outer race. This moves the rollers a few thousandths of an inch imparting

relative angular motion between the roller cage and cam. This slight movement of the rollers into the deeper cam zones, with a clean lubricant film wedged between rollers and outer race, permits freewheeling without metal to metal contact.

At rest (or at any synchronous speed of the input and output shafts), the spring actuated roller cage, Illustration 1, has already positioned the rollers into the contact zone. All rollers have been positively guided to engage uniformly and maintain their relative positions accurately to assure uniform load distribution. The rollers then engage in compression between the precision ground and hardened, cam plane surfaces and the inside diameter of the outer race. When the clutch is in this "engaged" or "driving" condition, the cam, rollers and outer race are locked and therefore, not subject to wear.

The two types of CECON Clutches are Type CEUS and Type CEUHS. Both contain similar standard clutch operating parts and therefore, operate in the same manner. The basic differences are the means of lubrication and method of bearing support.

Type CEUS CECONS are ball bearing supported at four points and are suitable for use on most applications. Lubrication is self-contained in the sealed housing and provides self-circulation and self-filtering through stainless steel filter strainers.

Type CEUHS CECONS have high speed turbine type, steel backed babbbitted bearings at four points which are lubricated by a customer supplied external lubrication system, through standard A.S.A flanged oil inlet and drain furnished on the housing. This bearing and lubrication arrangement permits higher operating speeds than the CEUS type.

Since the Type CEUS CECON is suitable for most applications, the following design and application information will be based on this type of unit. However, the type CEUHS is readily available for speeds above the CEUS limits or wherever a sleeve bearing supported unit is preferred.

Disconnect Feature

Both CEUS and CEUHS CECONS are available with a disconnect feature that provides physical separation of the input and output shafts. This allows maintenance to be performed on the non-energized driver while the disconnect CECON is locked out in the disconnect position.

Other features include:

- View port which allows visual confirmation of disconnect/connect status
- Full-speed testing of isolated equipment prior to reconnection
- Direct replacement for existing CEUS and CEUHS units



Illustration 2

Coverplate and bearing have been removed to show the roller cage that maintains the rollers in their optimal position.

Design Feature

The basic clutch elements of cam, roller cage and outer race are similar items as employed for other Marland Clutches. In addition, CECON Clutches are designed to keep freewheeling clutch parts and bearings adequately lubricated.

Housings are of rugged, cast construction with liberal cooling areas to permit dissipation of heat which may be generated during high speed freewheeling operation. The stationary housing also provides a large oil reservoir with many times the oil capacity of an ordinary freewheeling clutch.

Provision is made against unnecessary churning of the oil. This is done by ample reservoirs to hold the excess oil volume out of the rotating clutch chamber during high speed operation. The oil, caught in the reservoirs, is cooled and is then recirculated in controlled volume from the bottom of these reservoirs.

In addition to permitting high shaft speeds and continuous uninterrupted operation, the following design features are equally important in certain applications.

Operation On Other Than The Horizontal Plane

Cement and other pyro kilns have drive systems that are not horizontal. Under these conditions a standard freewheeling clutch coupling might tend to lose its lubricant while the shafts were not in a horizontal plane.

Problem Atmospheres

CECON Clutches are also intended for use on stationary, horizontal applications where extreme atmosphere pollution caused by outdoor sand, dust and wind action, rain or sleet might contaminate the lubricant in a standard freewheeling clutch coupling. Even if some such contamination should inadvertently pollute the lubricant in a CECON Clutch, means for sedimentation of such foreign matter are provided in the lubricant reservoir and fittings. Gravity separation permits withdrawal of the impurities from the lubricant without interrupting continuous operation.

Maintenance

CECON Clutches Type CEUS are continuously self-lubricated without the use of pumps or external piping. The self-circulating lubricant is also self-filtering by continuous gravity flow through 100-mesh stainless steel filter-strainers. Means are provided for easy renewal of the filtering elements. The only dependence on the human element is that of visually checking oil level, occasional sampling for oil purity and cleaning of filter strainers, none of which requires shut-down of the equipment. A breather-filter is provided to compensate for barometric and temperature changes.

Oil Sampling

A drain valve on the easiest-to-reach side of the CECON Clutch permits sampling of the lubricant to help detect the presence of any contaminant and draining if necessary.

Equipment which must operate in cement mills, chemical plants, highly humid plant areas, or in high ambient temperatures or similar problem atmospheres are well served by CECON Clutches even though uninterrupted operation is not compulsory.

Free Rotation

The cylindrical rollers used in all Marland Clutch products are free to rotate in their individual pockets during freewheeling permitting the load to be engaged and re-engaged on any part of the roller circumference and cylinder surface.

Lower Stress

When roller and cam are engaged under compressive loading, the load is uniformly distributed over a large zone of contact with consequently lower stresses to result in more durable, efficient operation.

Accurate Dimensions

Cylindrical rollers are easy to produce and reproduce to precision dimension limits which are readily checked with micrometers, go-no-go gauges, or if necessary, with the extreme closeness of light band inspection.

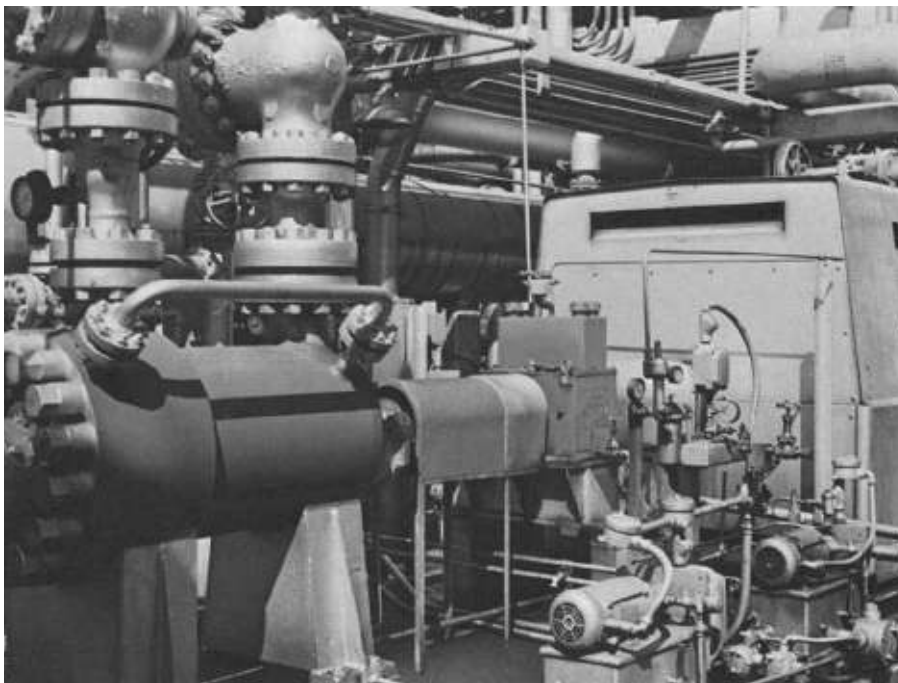

Photo: A Marland CECON clutch in an unprotected outdoor location at a West Coast hydrocarbon processing plant.

Advantages of Marland Cylindrical Rollers on Flat Inclined Cam Surfaces

Marland CECONs are a complex design that has been optimized to provide a longer operating life with less maintenance. Here are some of the major clutch components and their key design features:

1. Cam

High Grade alloy steel, deep case hardening, precision machined

- Selected for optimal strength and wear resistance
- Heat treated to values which exceed competition, maximize peak torque capacities

2. Roller Assembly

High Grade alloy steel, through hardened, precision ground

- Designed to enhance load capacity
- Eliminates backlash
- Minimizes heat generation

3. Outer Race

High Grade forged alloy steel, deep case hardening, precision machined

- Lower hoop stresses leading to greater clutch peak capacity
- Better load distribution through length of torque transmitting elements
- Higher torsional stiffness of clutch assembly and less torsional wind-up

The section view below shows many of the engineered features that result in longer operating life in continuously operating applications.

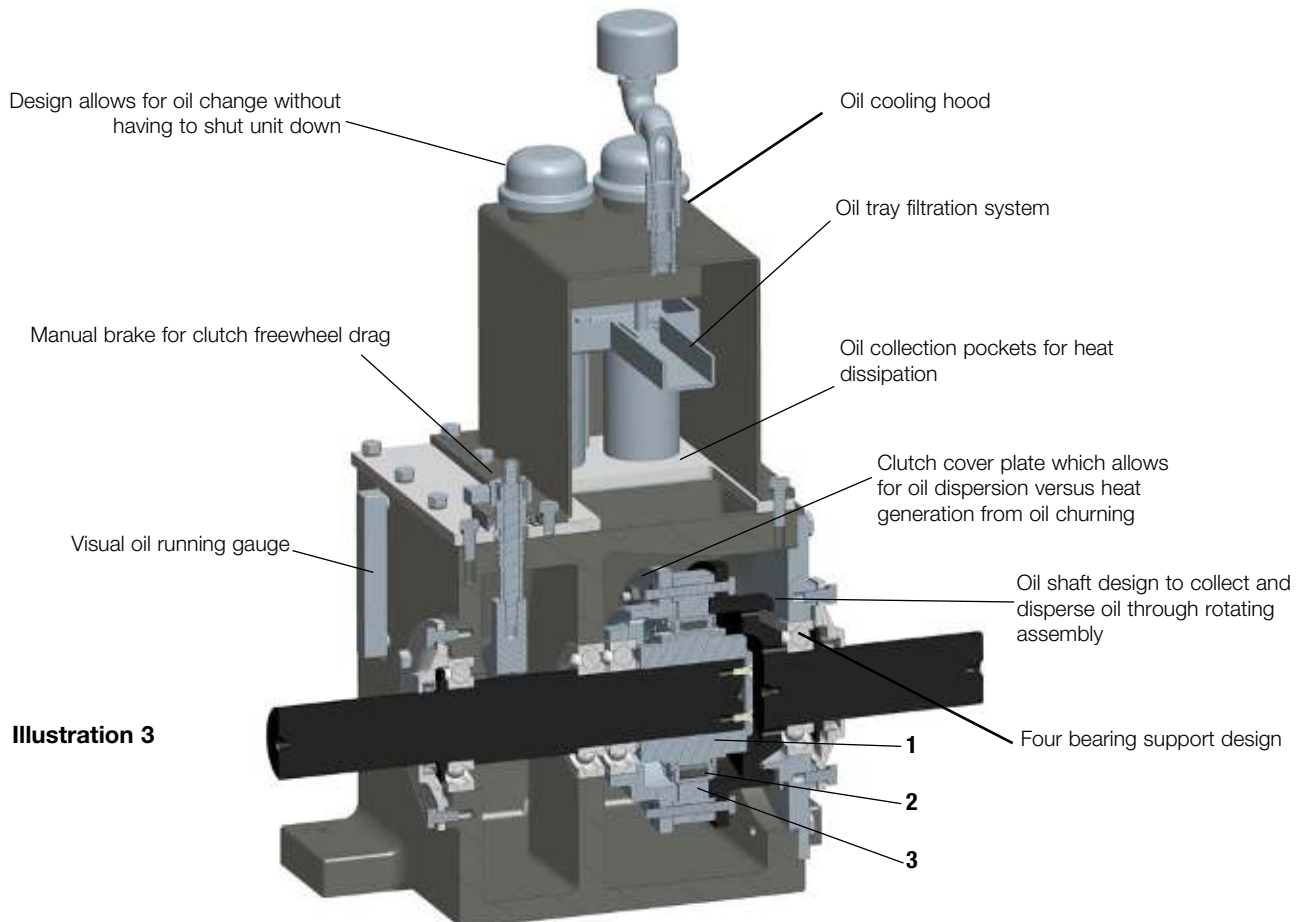

Illustration 3

Typical Applications

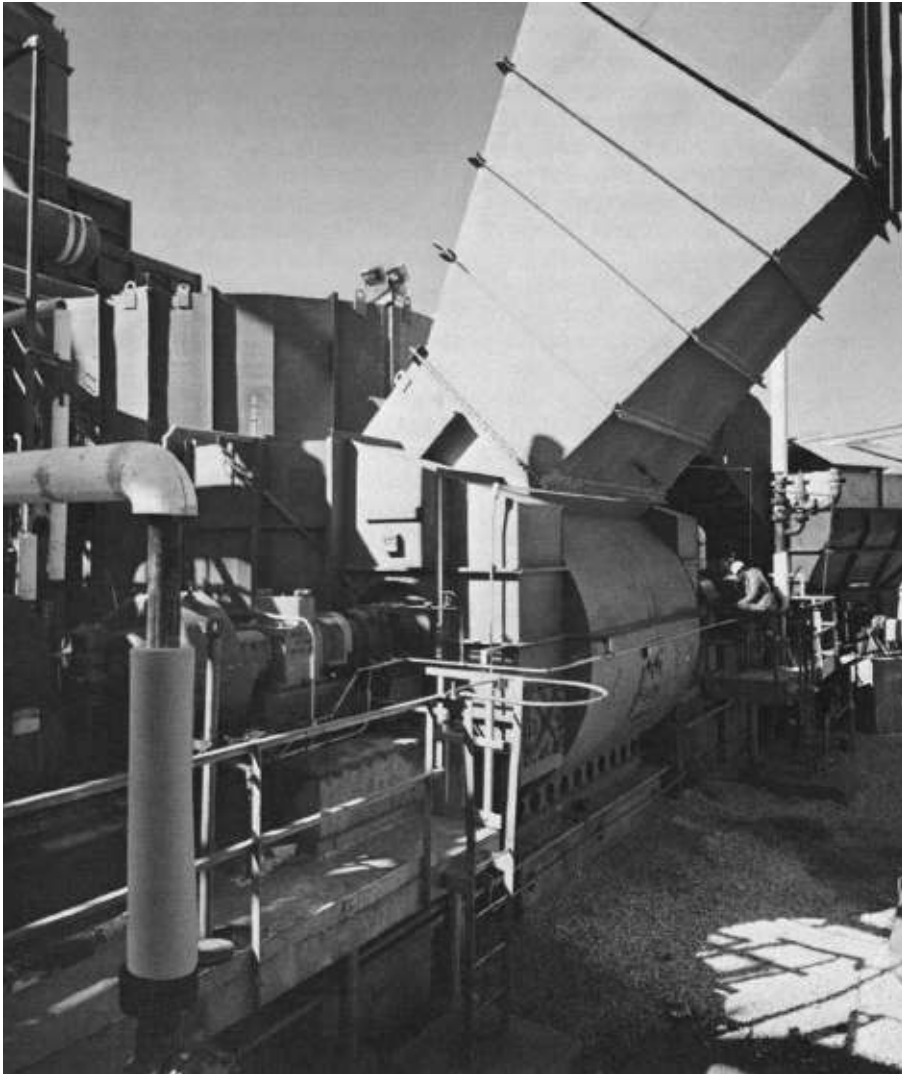

Photo: Dual driven induced draft fan through Marland CECONS to provide process steam at a Southern chemical plant

Dual Drives

For dual drive arrangements, CECON Clutches connected between the driven equipment and the power sources, provide for instantaneous changeover from one source of power to the other without delays for manually loosening, tightening or shifting standby drive connections. In Illustration 4, a large electric motor and steam turbine are connected to double shaft extensions of a continuously operating high speed pump through Marland CECON Clutches. The following operating modes exist:

1. Either the motor or the steam turbine may be used to drive the pump.
2. Both motor and turbine may share the pump load, depending on torque and speed characteristics of the prime movers.
3. If the motor is driving the pump at rated speed, the load may be taken over by the turbine without slowing down the pump. If required, the turbine may be used to increase the pump speed above the rated motor speed, but within permissible clutch speed rating, after which the motor may be shut off.
4. The turbine alone may drive the pump at any permissible clutch speed to suit varying operating demands.

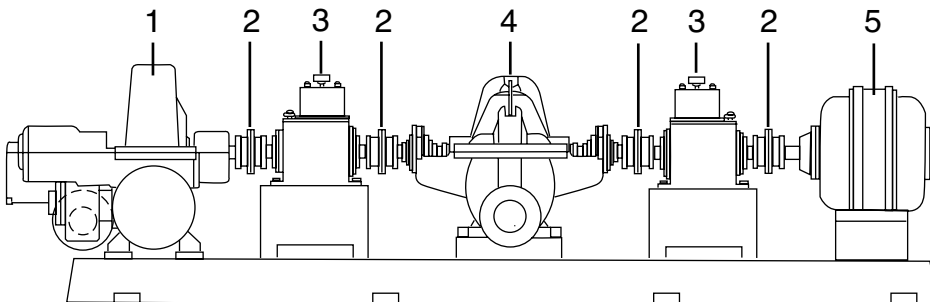

Illustration 4

1. Turbine
2. Flexible Coupling
3. Marland CECON Clutch
4. Compressor Pump or Blower
5. Motor

Inching or Creep Drives

A Marland CECON Clutch connected between a low speed drive and the normal operating speed drive for conveyors, steel strip mills, or other equipment, will permit operation at inching or creeping speed for inspection or servicing. Such drives are necessarily limited to one direction of rotation and cannot be reversible.

CECON clutch allows automatic and instantaneous change-over from one drive to the other without complex controls. The application of a Marland CECON Clutch to provide inching speed for an inclined conveyor is shown in the Illustration to the right. Such very low speed drives may be required where exposure to freezing temperatures prevents restarting, if not kept in constant slow motion.

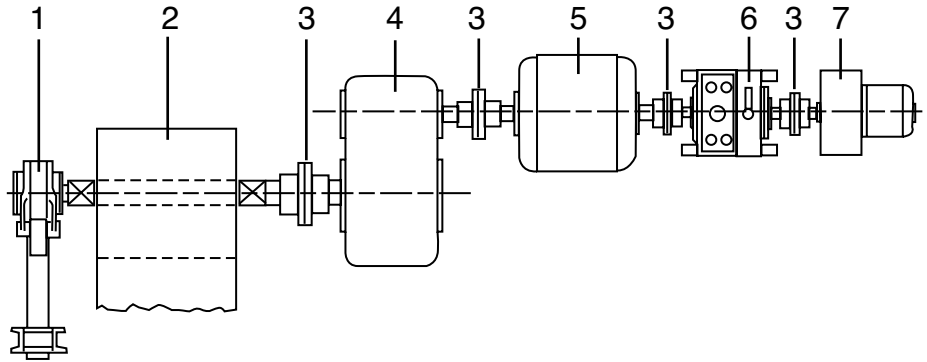

Illustration 5

1. Marland Backstop
2. Conveyor Belt Headshaft
3. Flexible Coupling

4. Main Speed Reducer
5. Main Motor
6. **Marland CECON Clutch**
7. Inching or Creep Drive Motor

Starter or Turning Gear Drives

Large, heavy-duty industrial fans often require turning gear drives to keep the fan impellers rotating slowly when the main drive is shut down. Without this slow rotation in high temperature applications, such as induced draft and hot gas recirculating fans, the impeller will heat or cool unevenly and distort the blades or shaft. In addition, slow rotation may be necessary to insure proper lubrication of fan bearings.

In some cases, the turning gear drive and the CECON clutch are size selected to start the fan from rest before the larger high-speed motor is turned on. (See Illustration 6)

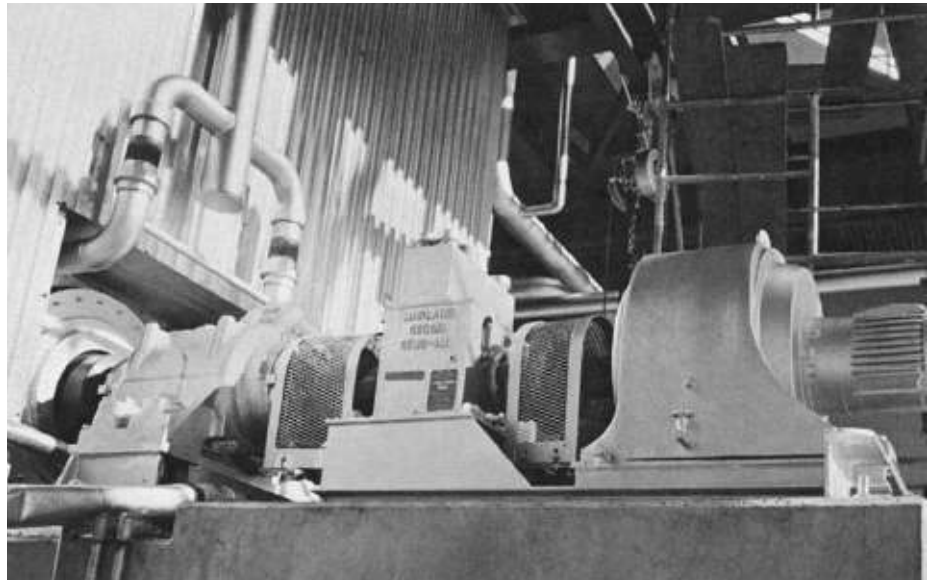

Photo: Hot gas recirculating fan turning gear drive through CECON clutch provides continuous slow rotation to prevent thermal distortion and keep fan bearings properly lubricated.

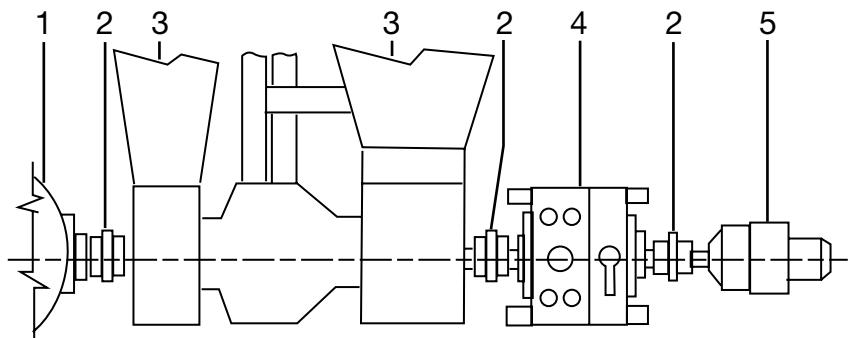

Illustration 6

1. Main Drive
2. Flexible Coupling
3. Fan or Compressor

4. **Marland CECON Clutch**
5. Turning Gear Drive

Typical Applications

Energy Recovery Systems

Energy recovery in hydrocarbon processing plants is an important factor in the reduction of operating costs. Wherever a high pressure liquid flow is reduced to a lower pressure, hydraulic energy is wasted. By the application of a hydraulic turbine and a CECON clutch, most of this energy can be recovered.

The hydraulic turbine is connected to the CECON Clutch input shaft, and the output shaft is connected to the double extended motor shaft or pump shaft. The motor is usually sized to carry the full pump load for those times, such as start-up, when little or no fluid is available to the hydraulic turbine. During these periods the CECON Clutch is freewheeling, allowing the hydraulic turbine to remain stationary.

As process fluid flow increases, the hydraulic turbine accelerates until it reaches the speed of the motor. The CECON clutch automatically engages to transmit hydraulic turbine torque to the motor, decreasing the motor current demand. The CECON clutch will automatically engage and disengage if the hydraulic turbine speed varies with the change in the flow of the process fluid.

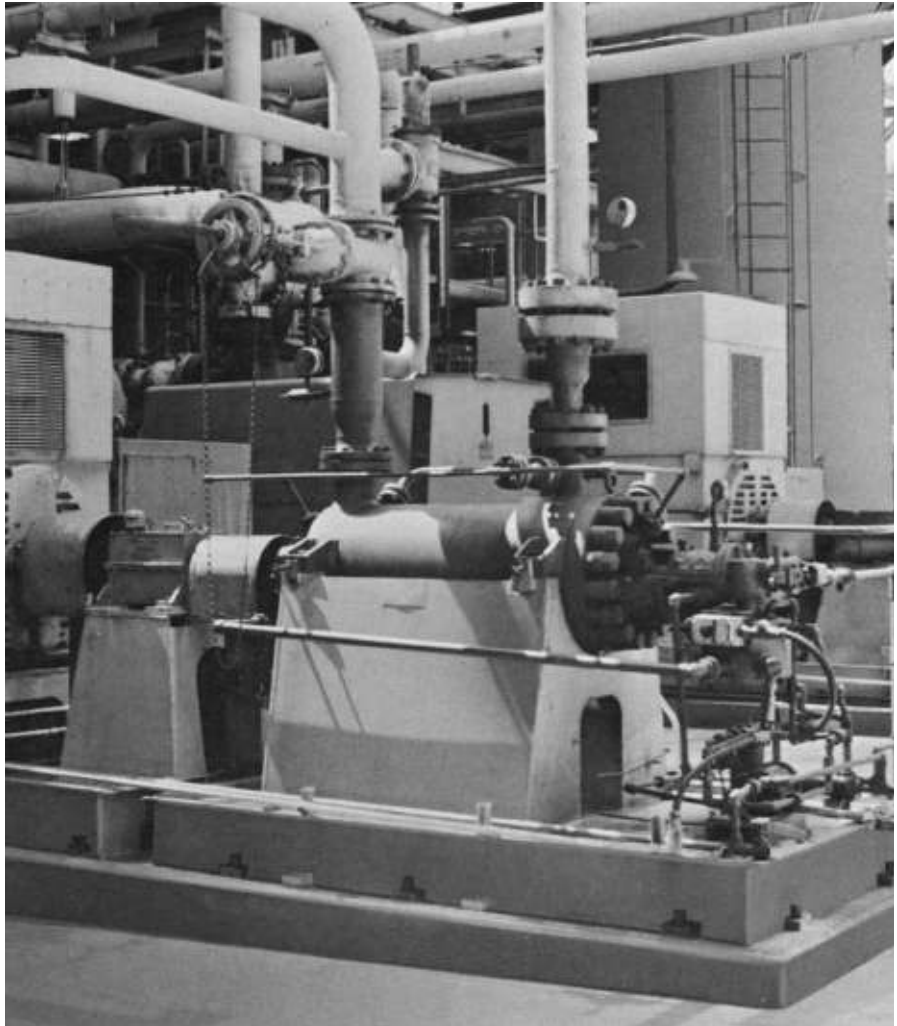

Photo: Two Type CEUHS CECON clutches at large Texas refinery used with hydraulic turbines to recover energy from process fluid

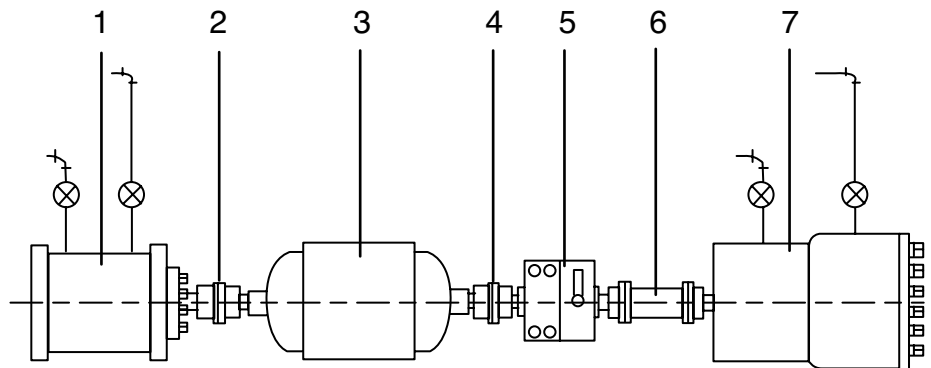

Illustration 7

- 1 Main Pump
- 2 Coupling
- 3 Main Motor
- 4 Gear-Type Coupling

- 5 **Marland CECON Clutch**
- 6 Gear-Type Spacer Coupling
- 7 Hydraulic Turbine

Kiln Emergency Drive

For some time the trend in the cement and other pyro-processing industries has been toward larger and more efficient kilns. Since these kilns operate 24 hours per day, month after month, it has been important to conserve power and avoid down time as much as possible.

The high degree of efficiency in the mechanical power transmission that has evolved also means that the kiln can roll back due to the large off-center mass of material in the kiln when power failure occurs or at any time the main drive is shut down. Uncontrolled rollback carries the danger of centrifugal explosion of the main drive components since they may be oversped to many times the normal forward speed.

Another consideration to be made during main drive shutdown is the prevention of kiln distortion due to the high temperatures. An emergency drive can be utilized to provide forward rotation at a reduced speed, both to prevent distortion and also to empty the contents of the kiln before it becomes impacted to the lining.

Marland CECON clutches and CEBMAG backstops provide automatic, remote emergency operation in case of main electric power failure. Their use provides controlled reversal of the kiln and automatic changeover to emergency drive for forward rotation at reduced speed.

The first Marland CECON clutch installed on a cement kiln went into operation over 35 years ago. Since that time many of the largest kilns in this country and throughout the world have been provided with CECON and CEBMAG units.

For more detailed information on CEBMAG backstops, refer to the CEBMAG catalog.



Photo: Marland CECON clutch and CEBMAG Backstop on modern cement kiln provide for emergency drive rotation in case of main power shutdown.

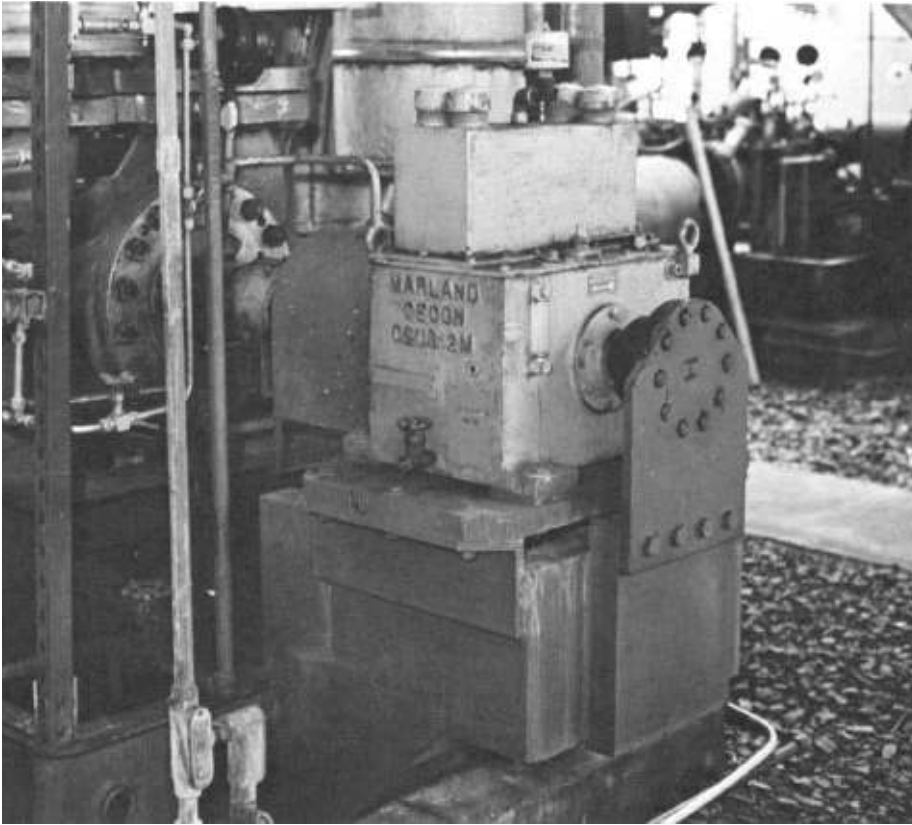

Photo: Marland backstop prevents reversal of pump if check valves should fail during power failure.

High Speed Backstops

Standard Marland backstops are recommended for use at low speeds, as on conveyor drive pulley shaft, instead of at motor speed or on other high speed shafts. However, there are many applications for backstops on equipment having only high speed shafts available. Examples of this type of application include motor or turbine driven pumps, compressors or blowers. When power failure or shutdown occurs, the common header for the air or fluid may cause reverse rotation of the equipment if check valves fail to shut off the reverse flow. During such reversals the equipment can rapidly accelerate to dangerously high speeds.

A CECON backstop will prevent reversal of the connected equipment, thereby guarding against the possibility of centrifugal explosion or other damage. CECON backstop units are provided with all the features as outlined for CECON clutches to permit continuous operation at medium to high speeds. The only modification is a torque arm attached to the CECON input shaft. The end of the torque arm is positively retained as shown in Illustration 8.

Special Requirements

In over 60 years as the recognized leader in the design and manufacturer of freewheeling clutches, the Marland engineering staff has been given many unusual and difficult requirements for clutches and backstops. This has resulted in special designs to meet those exacting requirements. If your needs cannot be filled by a standard item, give us the engineering details. It may be that we already have the solution to your problems, and if not, we'll go to work and find one.

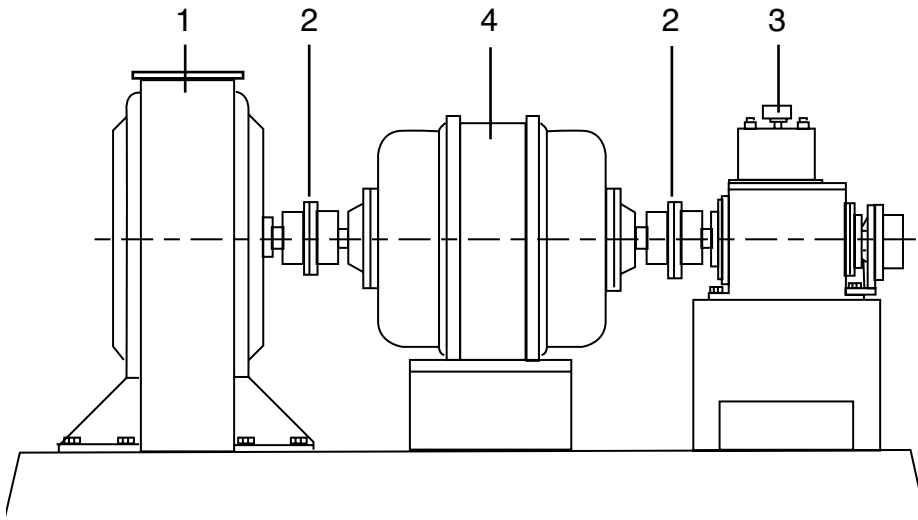

Illustration 8

- 1 Compressor, Pump, or Blower
- 2 Flexible Coupling
- 3 Marland CECON Highspeed Backstop
- 4 Motor

Selection of a Marland CECON Clutch requires the following information:

1. Nameplate horsepower of drive (motor, turbine, engine, etc.)
2. RPM of driving shaft.
3. RPM of driven shaft (freewheeling speed)
4. Kind of machines to be connected (driving and driven)
5. Direction of driving rotation when facing input end of CECON.
6. Where the CECON Clutch shafts will not be on a horizontal plane, refer to the factory indicating angular position.
7. For dual drive arrangements requiring a second CECON Clutch, similar information as outlined above applying to the alternate drive should be obtained to assure selection of a proper size CECON Clutch for the alternate driver.

Note:

High Speed Operation

CEUS CECON clutches overrunning or driving at speeds above those shown below may require matching or balancing of components for proper operation and long life. Consult factory for restriction and additional costs.

CEUS-5C-8M	1,800 RPM
CEUS-12M-30M	1,200 RPM
CEUS-42M-60M	900 RPM

Selection Procedure

1. Calculate the normal load torque (T) in pound-feet

$$T = \frac{\text{Nameplate Horsepower} \times 5,250}{\text{RPM of Clutch Input Shaft}}$$
2. Select the proper service factor (SF) from Table based on actual connected equipment or by the class of service most closely resembling the service conditions under consideration. If an exact or similar application is not shown in Table, or if special conditions exist, refer to Home Office with complete information.
3. Multiply the normal load (T) by service factor (SF) to obtain the required clutch torque.
4. Refer to the CECON capacity ratings as shown on Page 11 for type CEUS, or Page 13 if type CEUHS is preferred or required by speed of application, and select the required size.

The shaft sizes of the driving and driven equipment need not be considered in selecting the CECON Clutch size since the CECON input and output shafts are to be connected to the driving and driven shafts through suitable sizes of double-engagement, self-aligning, gear-type flexible couplings. If Marland is to furnish the couplings, the micrometer shaft diameters and keyseat dimensions of the driving and driven equipment must be furnished to assure proper coupling selection.

Service Factors

The following service factors are for typical applications shown in this catalog. They are not intended as a firm recommendation, but are offered only as a general guide:

Motor and Turbine Driven-Dual Drives:

Forced Draft Fans	1.50
Induced Draft Fans	1.50
Centrifugal Pumps	1.50
Inching or Creep Drives	1.50
Starter or Turning Gear Drives	1.50
Energy Recover Systems	1.50
Kiln Emergency Drives	1.25

Engine Driven—refer to Factory

Applications not shown – contact the Factory.

Marland CECON Clutches Type CEUS

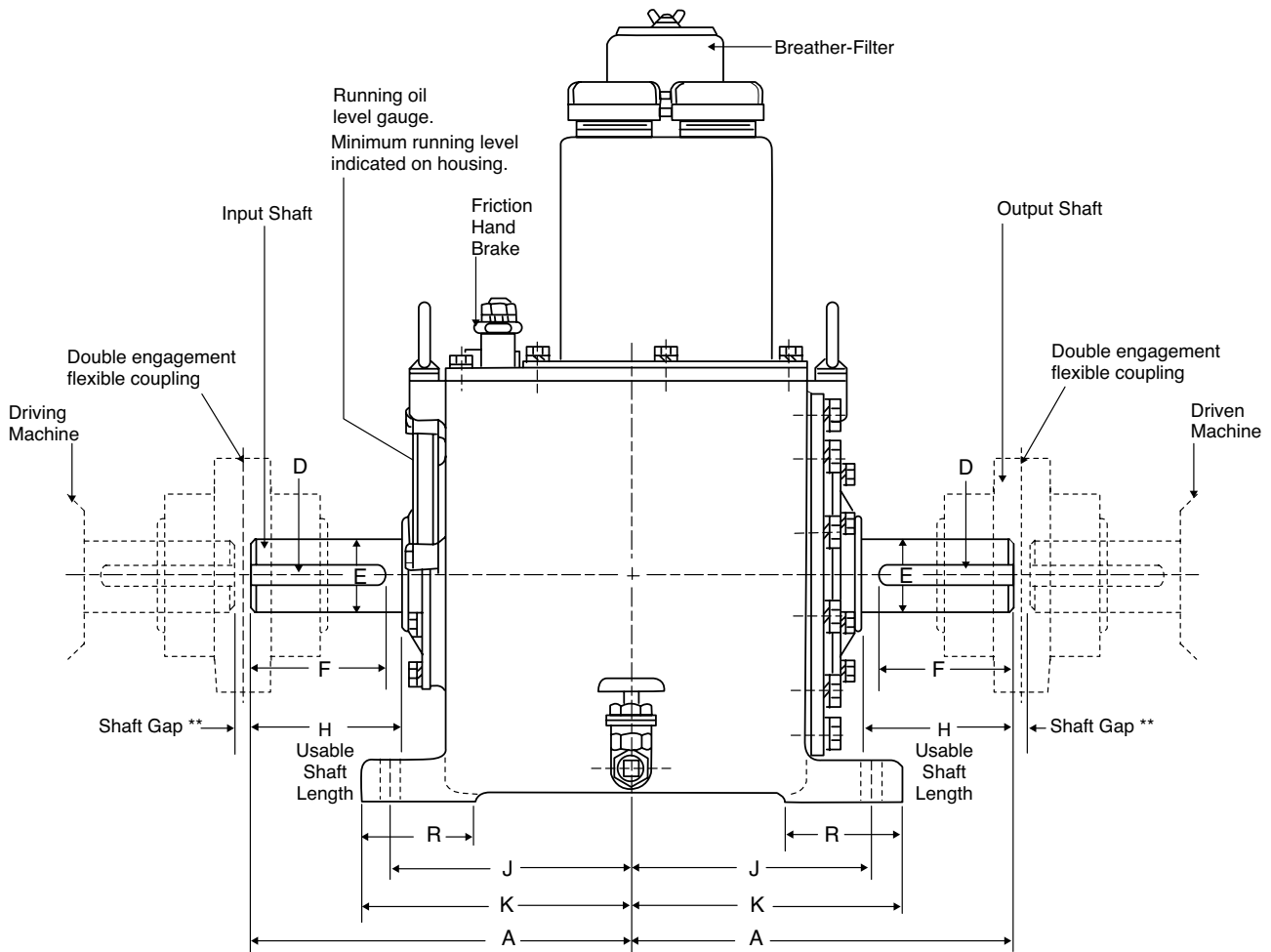

CECON Clutch CEUS Type	Rated Torque lb. ft.	Capacity HP Per 100 RPM	# RPM Maximum	Approx. Oil Capacity qts.	Ship Wght. lbs. (Less Cplgs.)
5C	500	9-1/2	6,000	5	220
1M	1,000	19	5,600	7	320
2M	2,000	38	4,200	12	440
4M	4,000	76	3,600	15	560
8M	8,000	152	3,000	22	780
12M	12,000	229	2,500	30	1,200
18M	18,000	343	2,300	50	1,600
30M	30,000	571	2,000	65	2,000
42M	42,000	800	1,700	80	2,500
60M	60,000	1,143	1,400	110	3,000

** Shaft gap per coupling manufacturer or customer specification

Consult applicable local and national safety codes for proper guarding of rotating shafts and couplings. For higher speeds, consult factory.

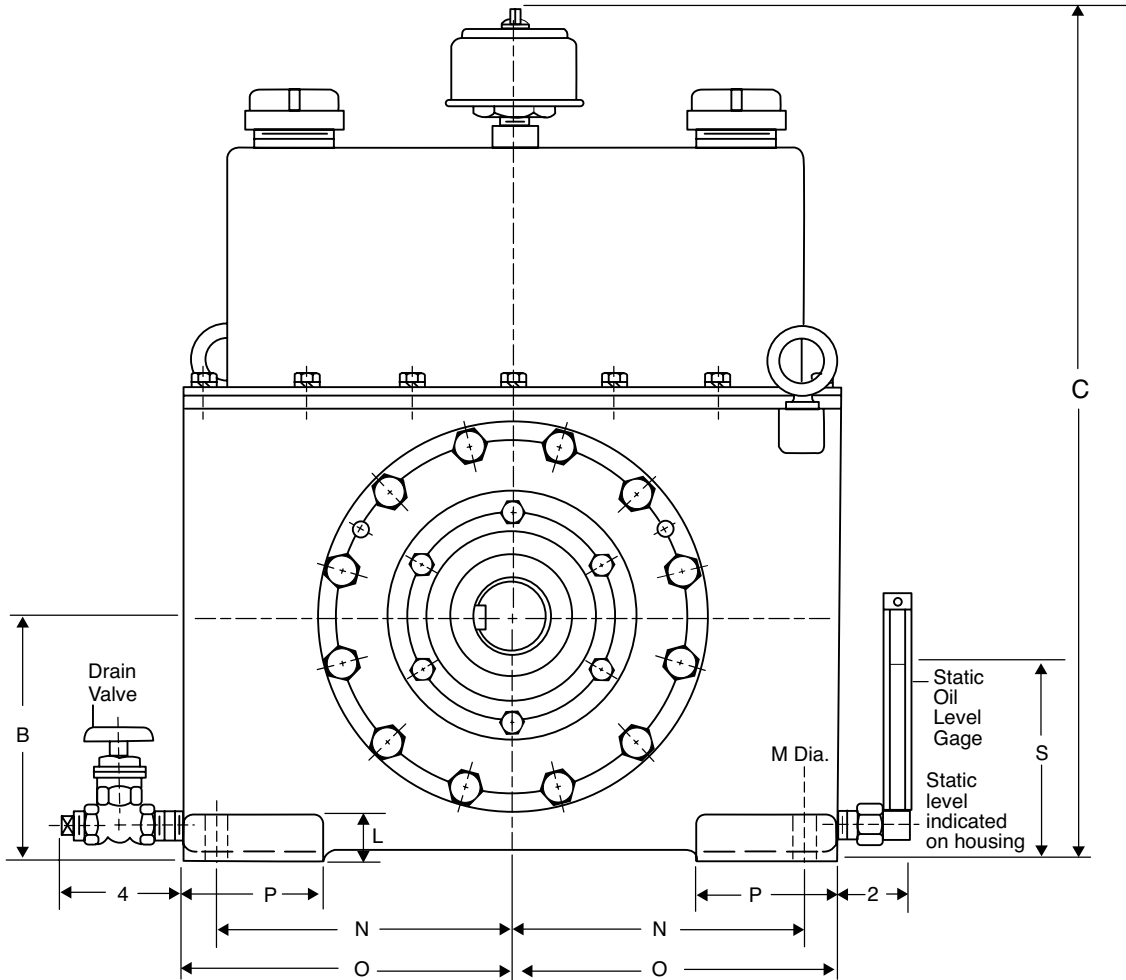

CECON Clutch

Dimensions in Inches

Clutch Type	A	B	C	D	*E	F	H	J	K	L	M	N	O	P	R	S
5C	8.50	4.75	21.50	0.37 x 0.19	1.5625	3.00	3.19	5.50	6.37	1.25	0.69	6.75	7.62	3.12	3.12	3.75
1M	9.81	5.75	23.50	0.37 x 0.19	1.7500	3.75	3.87	6.37	7.25	1.25	0.69	6.37	8.12	3.50	3.50	4.62
2M	11.62	6.87	25.50	0.62 x 0.31	2.3125	4.50	4.62	7.37	8.25	1.25	0.69	8.37	9.37	4.00	3.50	5.50
4M	12.81	7.75	27.50	0.62 x 0.31	2.7500	5.25	5.37	7.75	8.75	1.25	0.69	9.00	10.00	4.00	4.00	6.12
8M	14.75	8.62	29.25	0.87 x 0.44	3.3125	6.00	6.12	9.12	10.25	1.50	0.81	8.75	10.75	4.00	4.00	6.75
12M	17.06	9.62	31.25	1.00 x 0.50	3.8750	6.75	6.94	10.75	11.87	1.50	1.06	9.12	11.37	4.50	4.50	7.50
18M	18.94	11.25	33.75	1.00 x 0.50	4.3125	7.50	7.69	11.62	12.87	1.75	1.31	10.25	13.00	5.00	5.00	8.87
30M	21.00	12.75	37.50	1.25 x 0.62	5.0625	8.50	8.62	13.12	14.75	1.75	1.31	12.75	15.50	5.50	5.50	10.00
42M	22.87	14.50	40.50	1.50 x 0.75	5.8750	9.00	9.12	14.37	15.87	2.00	1.31	14.50	17.50	6.00	6.00	11.25
60M	24.75	16.00	43.50	1.75 x 0.87	7.0000	10.50	10.62	15.25	16.75	2.00	1.31	16.00	19.00	6.00	6.00	12.25

* Shaft dia. + .0000/-0.0010, Coupling bore -.0010/-0.0015

Marland CECON Clutches Type CEUHS

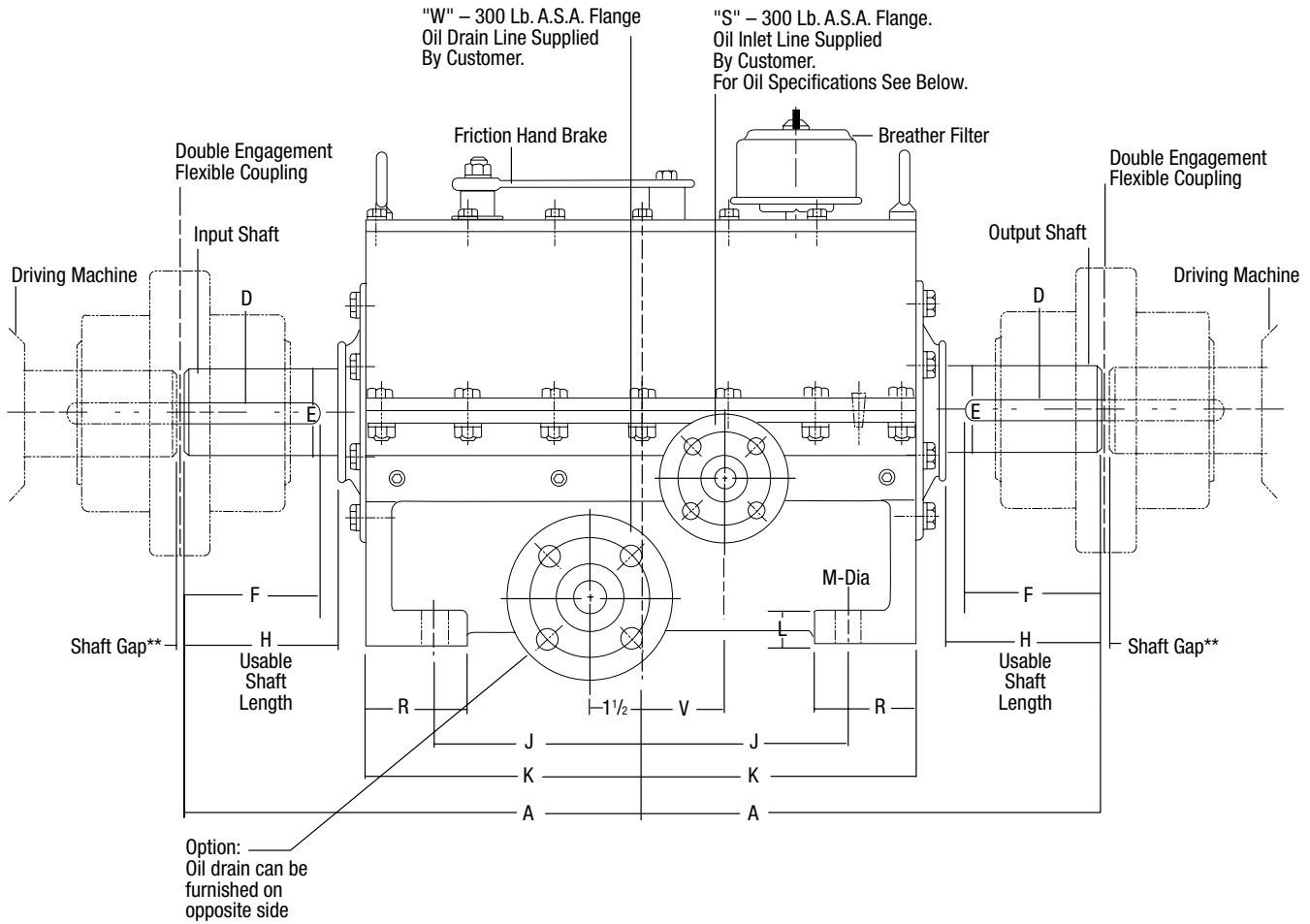

CECON Clutch CEUHS Type	Rated Torque lb. ft.	Capacity HP Per 100 RPM	# RPM Maximum	Oil Supply Gals. Per Min. +	Ship Wght. lbs. (Less Cplgs.)
1M	1,000	19	12,000	2-1/2	250
2M	2,000	38	10,000	3-1/2	400
4M	4,000	76	8,000	4-1/2	700
8M	8,000	152	7,000	7	1,200
12M	12,000	229	6,000	9	1,700
18M	18,000	343	5,000	11	2,500
30M	30,000	571	4,500	14	3,200
42M	42,000	800	4,000	18	4,600
60M	60,000	1,143	3,500	23	6,100

Consult applicable local and national safety codes for proper guarding of rotating shafts and couplings.

** Shaft gap per coupling manufacturer or customer specification

For higher speeds consult factory.

+ To be supplied by customer: This quantity of regular turbine oil of approx. 150-250 S.S.U. at 100 degree F., at 15-20 P.S.I. pressure, at a max. inlet temp. of 110 degree F., filtered to 10-15 microns.

Units can be furnished with proximity probes and/or RTD's.

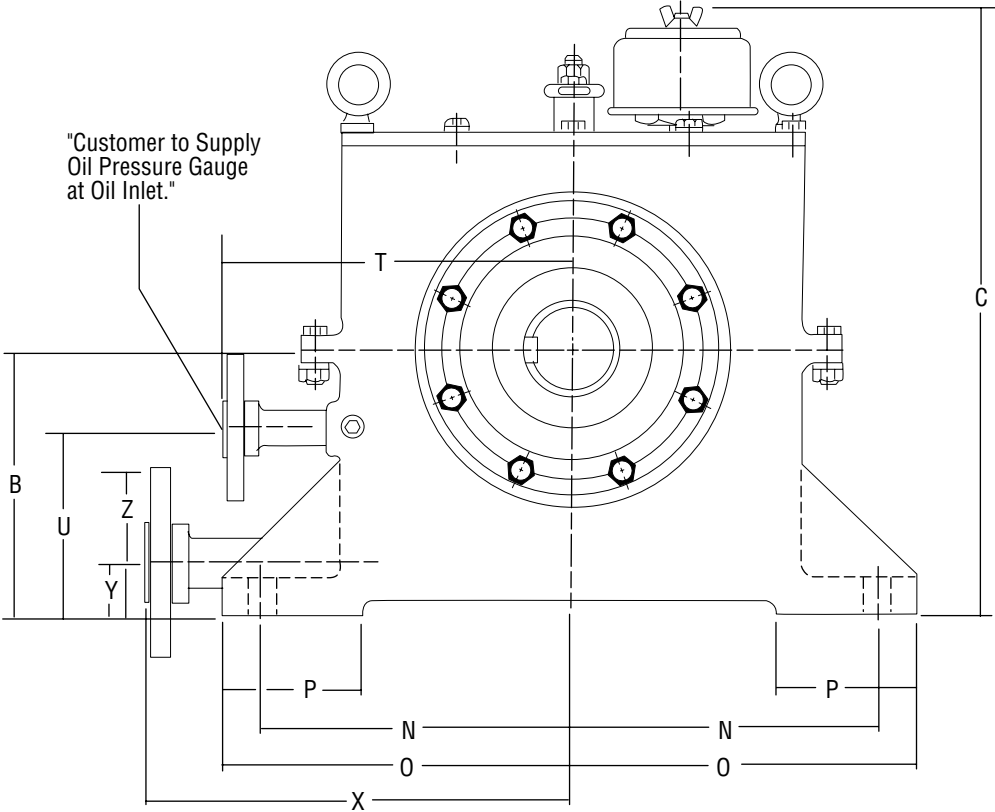

CECON Clutch	Dimensions in Inches																						
Ceus Type	A	B	C	D	*E	F	H	J	K	L	M	N	O	P	R	S	T	U	V	W	X	Y	Z
1M	12.37	5.75	14.62	.50 x .25	2.0000	3.75	3.87	6.379	7.69	1.00	0.69	6.37	7.25	3.00	3.00	0.50	8.25	3.75	2.62	1.25	9.25	1.37	5.25
2M	14.56	6.87	16.37	.62 x .31	2.5000	4.50	4.62	7.37	9.12	1.00	0.69	8.37	9.25	4.00	3.50	0.50	9.25	4.87	3.12	1.50	11.25	1.50	6.12
4M	17.19	7.75	18.25	.87 x .44	3.3125	5.25	5.37	7.75	10.94	1.25	0.69	9.00	10.50	4.00	4.00	0.75	10.87	5.44	3.62	2.00	12.50	1.75	6.50
8M	21.56	8.62	20.75	1.00 x .50	4.3125	6.75	6.94	11.50	13.69	1.25	0.81	10.75	11.75	4.50	4.50	0.75	12.12	5.37	4.62	2.00	13.75	1.75	6.50
12M	24.56	9.62	22.62	1.25 x .62	4.8125	7.50	7.69	12.75	15.37	1.50	0.81	12.00	13.00	5.00	5.00	1.00	13.12	5.94	5.31	2.50	16.00	2.25	7.50
18M	26.87	11.25	25.75	1.50 x .75	5.5625	8.44	8.37	14.00	16.69	1.50	1.06	13.75	15.00	5.50	5.50	1.00	15.12	7.06	5.75	2.50	18.00	2.25	7.50
30M	31.75	12.75	28.75	1.50 x .75	6.2500	10.37	10.62	16.50	19.62	1.50	1.06	15.75	17.00	6.00	6.00	1.00	16.62	8.06	7.00	3.00	20.00	2.50	8.25
42M	34.94	14.25	30.25	1.75 x .87	7.2500	11.56	11.81	18.25	21.62	1.50	1.31	17.00	18.50	6.50	6.50	1.25	17.62	8.87	7.75	3.00	21.50	2.50	8.25
60M	38.12	15.50	33.50	2.00 x 1.00	8.2500	12.62	12.87	20.25	23.75	1.50	1.31	18.00	19.75	7.00	7.00	1.25	18.37	9.50	8.50	3.50	22.75	3.00	9.00

* Shaft dia. + .0000/-0.0010, Coupling bore -.0010/-0.0015

Marland CECON Clutches Type CEUS

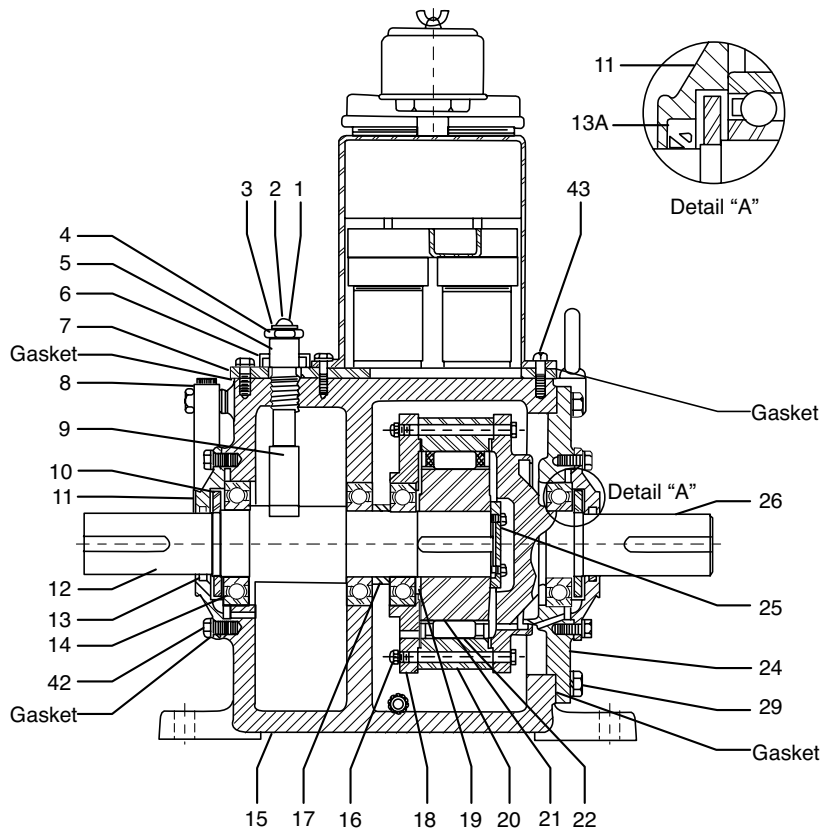

Part	Description
1	Brake Stud Nut
2	Brake Stud
3	Brake Stud Washer
4	Brake Handle
5	Brake Thrust Screw
6	Brake Seal Cover & Seal
7	Housing Cover & Gasket
8	Running Oil Level Gage
9	Brake Shoe
10	Oil Slinger
11	Shaft Seal Cover & Gasket
12	Input Shaft
13	Shaft Packing 13A Oil Seal
14	Ball Bearing
15	Clutch Housing
16	Bolts & Locknuts for 20
17	Bearing Spacer
18	Clutch Coverplate
19	Cam Spacer
20	Outer Race & Gaskets
21	Cam
22	Clutch Roller Assembly
23	Drain Valve
24	Housing End Plate & Gasket
25	Cam Retainer & Fasteners
26	Flange Output Shaft
27	Oil Flow Plug
28	Clutch Stop Lug
29	Screws & Lockwashers for 24
30	Housing Hood & Gasket
31	Oil Strainer Basket
32	Oil Strainer Housing
33	Oil Tray
34	Oil Strainer Stem
35	Strainer Inspection Cap
36	Breather-Filter
37	Pipe Nipple
38	Clutch Spring
39	Clutch Cam Key
40	Static Oil Level Gage
41	Eye Bolt
42	Screws & Lockwashers for 11
43	Screws & Lockwashers for 7

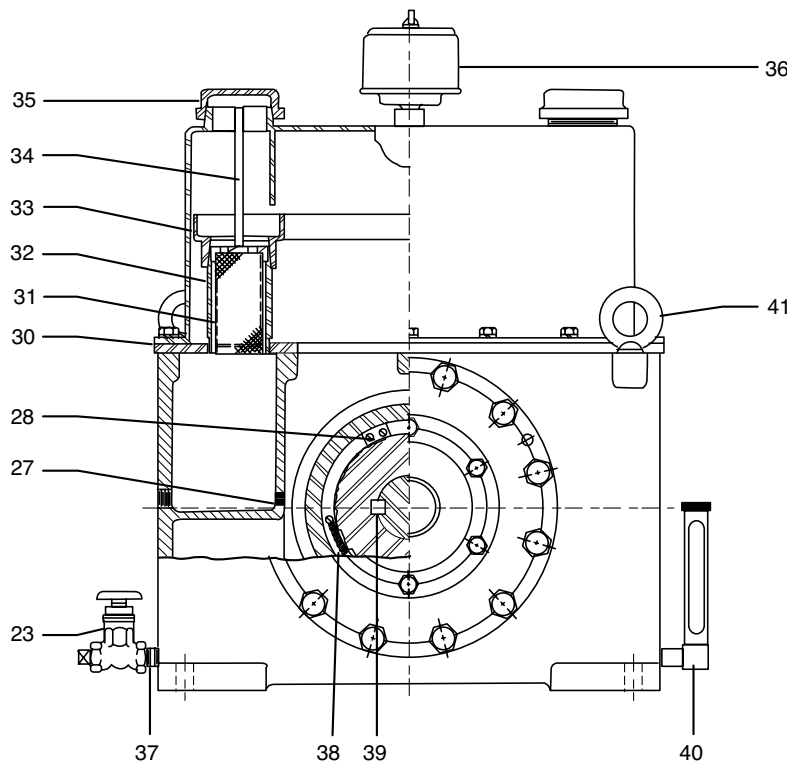

Consult applicable local and national safety codes for proper guarding of rotating shafts and couplings.

Marland CECON Clutches Type CEUHS

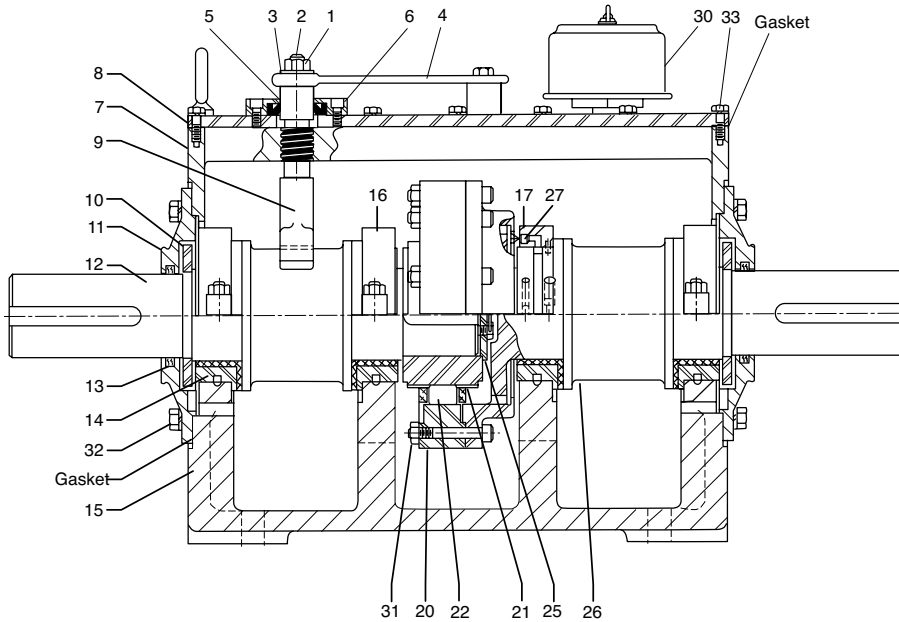

Part	Description
------	-------------

1	Brake Stud Nut
2	Brake Stud
3	Brake Stud Washer
4	Brake Handle
5	Brake Thrust Screw
6	Brake Seal Cover & Seal
7	Clutch Housing Cover
8	Inspection Cover
9	Brake Shoe
10	Oil Slinger
11	Packing Seal Cover & Gasket
12	Input Shaft
13	Shaft Packing
14	Shaft Bearing & Fasteners
15	Clutch Housing
16	Bearing Cap
17	Bearing Cap with Oil Flow
18	Oil Inlet Flange
19	Oil Drain Flange
20	Clutch Outer Race
21	Clutch Cam
22	Clutch Roller Assembly
23	Clutch Spring
24	Clutch Cam Key
25	Cam Retainer & Fasteners
26	Flanged Output Shaft
27	Clutch Oil Flow Plug
28	Clutch Stop Lug
29	Eye Bolt
30	Breather-Filter
31	Bolts & Locknuts for 20
32	Screws & Lockwashers for 11
33	Screws & Lockwashers for 8
34	Fasteners for 16 & 17
35	Fasteners for 7

Consult applicable local and national safety codes for proper guarding of rotating shafts and couplings.

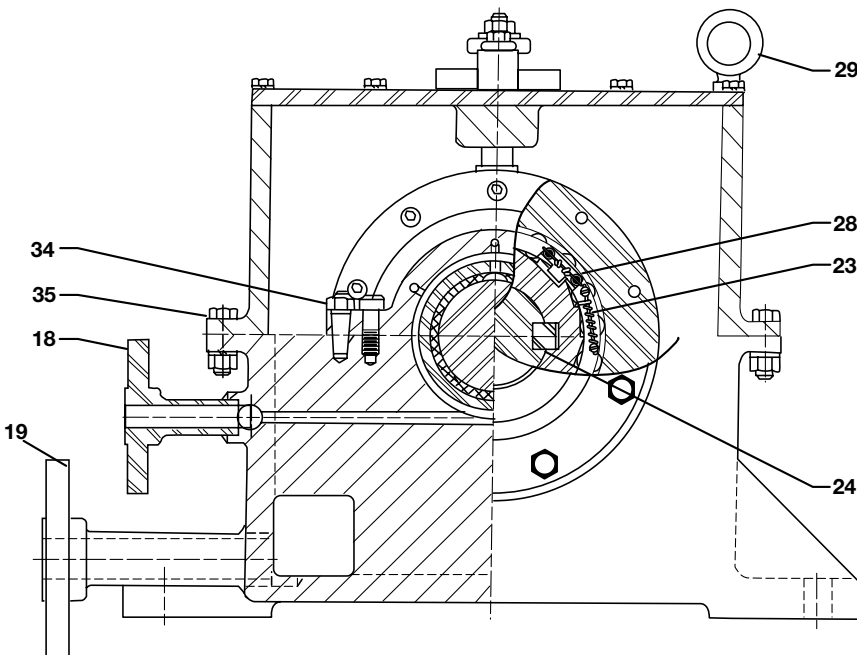

Marland CECON Disconnect Clutch

The Disconnect CECON is a completely mechanical overrunning clutch. It has been designed as a “no downtime” power transmission product. The Disconnect CECON is well suited for applications that demand uninterrupted operation or in hostile environmental conditions. Like all other Marland CECON clutches, it has been engineered to provide long and reliable life with a minimum of maintenance.

Features

- Complete physical separation of the input and output shaft
- Torque ratings to 60,000 lb/ft
- Speeds to 12,000 RPM
- Manual mechanical disconnect
- Total system isolation (US PAT.)
- Visual confirmation of lockout

Benefits

- Long life
- High reliability
- Minimum maintenance
- Allows maintenance of isolated equipment
- Permits full speed testing of isolated equipment
- Re-connection without system shut down
- Direct replacement for existing CEUS & CEUHS units

The need for CECON Clutches

Marland One-Way CECON Clutches are designed for applications where one or more of the following conditions exist:

1. Shaft speeds exceed the permissible maximum for standard clutches, clutch couplings, or backstops.
2. Uninterrupted, continuous operation is required.
3. Operation under extremely wet, dusty, abrasive or other adverse atmospheric conditions; or on unprotected outdoor applications; or subject to high ambient temperatures.
4. Shaft axis is not horizontal, as on cement kiln drives.
5. Lubrication maintenance must be provided on a no “downtime” basis.

CECON Clutches consist of a completely enclosed housing with provisions for supporting a Marland freewheeling clutch between two shafts, each of which is separately supported. The input shaft is connected to the cam and the output shaft is connected to the outer race.

The CECON shafts are then connected to the driving and driven equipment shafts through double engagement, self-aligning, gear-type flexible couplings.

During freewheeling, the outer race is free to rotate with the output shaft. The cam and roller assembly connected to the input shaft remain stationary, or rotate at a speed slower than the output shaft. An oil film wedges and separates the rollers from the outer race. This moves the rollers a few thousandths of an inch imparting relative angular motion between the roller cage and cam. This slight movement of the rollers into the deeper cam zones, with a clean lubricant film wedge between roller and outer race, permits freewheeling without metal to metal contact.

At rest (or at any synchronous speed of the input and output shafts), the spring actuated roller cage has already positioned the rollers into the contact zone. All rollers have been positively guided to engage uniformly and maintain their relative positions accurately to assure uniform load distribution. The rollers then engage in compression between the precision ground and hardened cam plane surfaces and the inside diameter of the outer race. When the clutch is in the “engaged” or “driving” position, the cam, rollers and outer race are locked and therefore, not subject to wear.

In addition, the disconnect CECON allows maintenance to be performed on the non-energized driver without system shutdown. This is accomplished by physically separating the input and output ends of the clutch, and providing a means for locking the clutch in the disconnect mode.

The two types of CECON Disconnect Clutches are Type CEUSD and Type CEUHSD. Both contain similar standard clutch operating parts and therefore, operate in the same manner. The basic differences are the means of lubrication and method of bearing support.

Type CEUSD Disconnect CECONS are ball bearing supported at four points and are suitable for use on most applications. Lubrication is self-contained in the sealed housing and provides self circulation.

Type CEUHSD Disconnect CECONS have high speed turbine type, steel backed babbbitted bearings at four points which are lubricated by a customer supplied external lubrication system, through standard A.S.A. flanged oil inlet and drain furnished on the housing. This bearing and lubrication arrangement permits higher operating speeds than the CEUSD type.

The Type CEUSD Disconnect CECON is suitable for most applications. However, the type CEUHSD is readily available for speeds above the CEUSD limits or wherever a sleeve bearing supported unit is preferred.

Disconnected

Illustration 9 depicts the clutch in the disconnected position. Note that the cam and roller assembly have been physically removed from the outer race, providing a separation of the input and output end of the clutch. In this position, the input end cannot be backdriven by the output end. It is also possible to test the isolated driver at operating speed before reconnection.

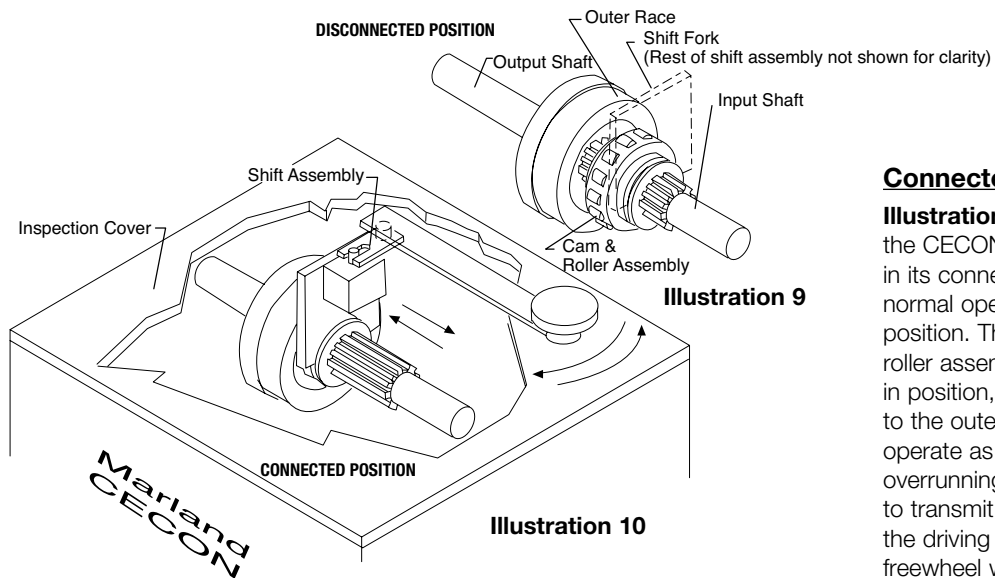

Illustration 9

Illustration 10

Connected

Illustration 10 shows the CECON clutch in its connected, normal operating position. The cam and roller assembly are in position, relative to the outer race, to operate as a normal overrunning clutch to transmit torque in the driving rotation or freewheel when the alternate energy source is actuated.

On January 2, 1990, OSHA Control of Hazardous Energy (Lockout/Tagout) in Volume 29 of the Code of Federal Regulation (29 CFR), Section 1910.147 went into effect. In general this rule requires that, "before servicing or maintenance is performed on machinery or equipment, the machinery or equipment must be turned off and disconnected from the energy source, and the energy-isolating device must be either locked or tagged out." OSHA provides these following definitions:

Energy-isolating device –

Any mechanical device that physically prevents the transmission or release of energy.

Lockout device –

Any device that uses positive means such as a lock, either key or combination type, to hold an energy-isolated device in a safe position, thereby preventing the energizing of machinery or equipment.

The Disconnect CECON meets the first condition by the physical separation of the input and output shafts, NOT by the mere locking of the input shaft to the clutch housing. The second condition is met when the clutch is locked by an authorized employee.

The Disconnect CECON is unique to the industry. While the main drive is in operation, maintenance can be performed on isolated equipment when the clutch is in a locked out position (as detailed in our service manual). The clutch has a lockout indication system, as well as a view port which allows for visual confirmation or disconnect/connect status.

The total system isolation feature also allows for the full speed testing of isolated equipment, at typical operating speeds, prior to reconnection. With the Disconnect CECON, removal and reinstallation of couplings is not required. This benefit means less time (and therefore less money) is associated with each maintenance outage.

To return to service, all that is required is the re-connection of the Disconnect CECON and the starting of the power train. This can be accomplished at any overrunning RPM.

The Disconnect CECONs are direct replacements for the equivalent sized CEUS and CEUHS units. This allows for the replacement of these non-lockout devices without requiring the expense of relocation of equipment. In summary, the CEUSD and CEUHS Disconnect CECON provides the best means to meet OSHA "isolation and lockout" requirements. The Disconnect CECON provides dollar savings with regard to the replacement of existing non-disconnect clutches without the related expense of equipment relocation. Additional savings are realized as the Disconnect CECON allows for both maintenance and full speed testing of isolated equipment. These benefits are coupled with MARLAND CLUTCH Division's continuous commitment to providing the most reliable and cost effective means of meeting the needs of the industry.

Marland Disconnect CEUSD CECON Clutch

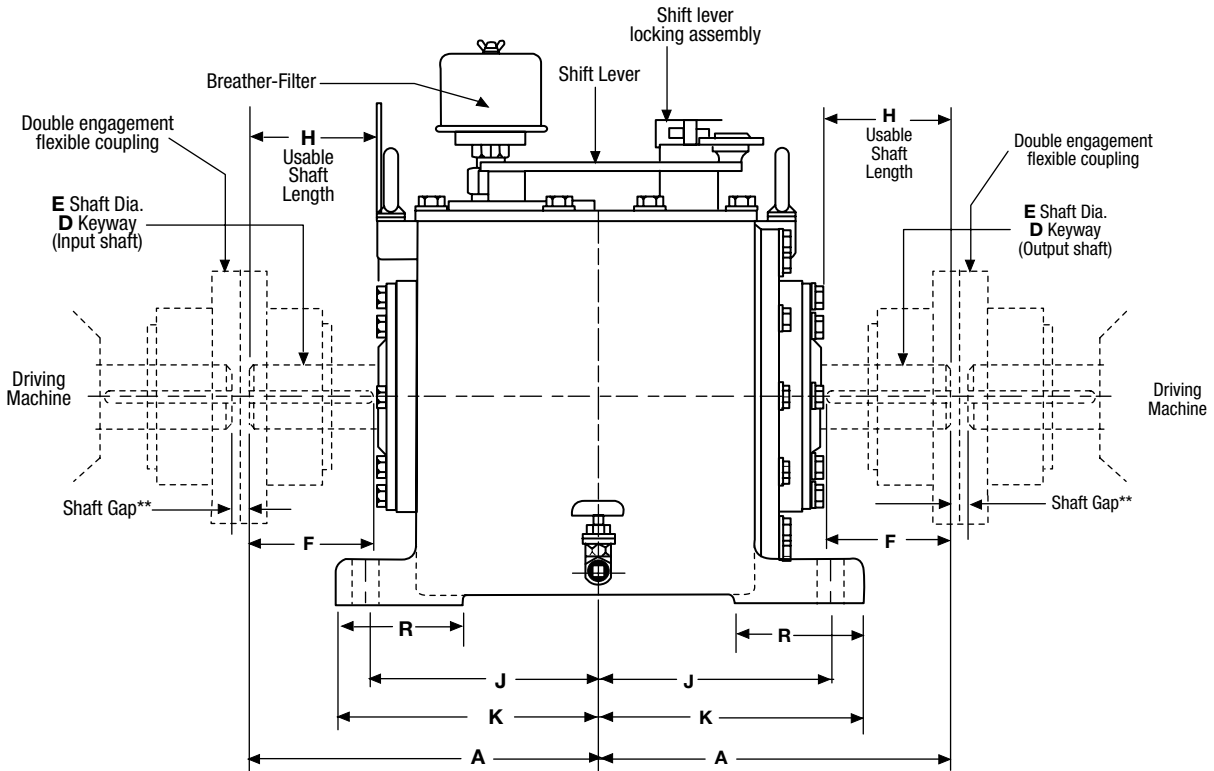

CECON Clutch CEUSD Type	Rated Torque lb. ft.	Capacity HP Per 100 RPM	RPM Maximum †	Approx. Oil Capacity Qts.	Ship. Weight lbs. (Less Cplgs.)
1M	1,000	19	5,600	7	320
2M	2,000	38	4,200	12	440
4M	4,000	76	3,600	15	560
8M	8,000	152	3,000	22	780
12M	12,000	229	2,500	30	1,200
18M	18,000	343	2,300	50	1,600
30M	30,000	571	2,000	65	2,000
42M	42,000	800	1,700	80	2,500
60M	60,000	1,143	1,400	110	3,000

Consult applicable local and national safety codes for proper guarding of rotating shafts and couplings.

** Shaft gap per coupling manufacturer or customer specification

† For higher speeds, consult factory

Marland Disconnect CEUSD CECON Clutch

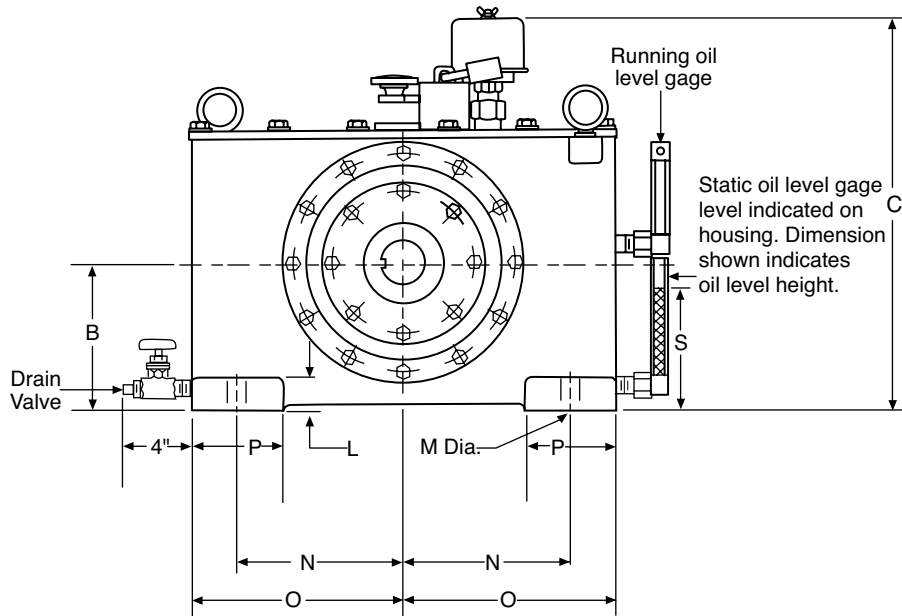

Dimensions inches (mm) – For Reference Only

Model	A	B	C	D	E*	F	H	J
1M	9.81 (249.24)	5.75 (146.05)	15.75 (400.05)	0.37 x 0.19 (9.53 x 4.78)	1.7500 (44.45)	3.62 (92.08)	3.62 (92.08)	6.37 (161.93)
2M	11.62 (295.28)	6.87 (174.63)	18.00 (457.20)	0.62 x 0.31 (15.88 x 7.95)	2.3125 (58.75)	4.12 (104.78)	4.25 (107.95)	7.37 (187.33)
4M	12.81 (325.45)	7.75 (196.85)	20.00 (508.00)	0.62 x 0.31 (15.88 x 7.95)	2.7500 (69.85)	4.75 (120.65)	4.87 (123.83)	7.75 (196.85)
8M	14.75 (374.65)	8.62 (219.08)	21.25 (539.75)	0.87 x 0.44 (22.23 x 11.13)	3.3125 (84.15)	5.87 (149.23)	6.00 (152.40)	9.12 (231.78)
12M	17.06 (433.40)	9.62 (244.48)	23.25 (590.55)	1.00 x 0.50 (25.40 x 12.70)	3.8750 (98.43)	6.37 (161.93)	6.50 (165.10)	10.75 (273.05)
18M	18.94 (481.03)	11.25 (285.75)	25.75 (654.05)	1.00 x 0.50 (25.40 x 12.70)	4.1250 (104.77)	6.75 (171.45)	6.75 (171.45)	11.65 (295.28)
30M	21.00 (533.40)	12.75 (323.85)	29.50 (749.30)	1.25 x 0.62 (31.75 x 15.88)	5.0625 (128.59)	7.87 (200.03)	8.00 (203.20)	13.12 (333.38)
42M	22.87 (581.03)	14.50 (368.30)	32.75 (831.85)	1.50 x 0.75 (38.10 x 19.05)	5.8750 (149.23)	8.37 (212.73)	8.50 (215.90)	14.37 (365.13)
60M	24.75 (628.65)	16.00 (406.40)	35.75 (908.05)	1.75 x 0.87 (44.45 x 22.23)	7.0000 (177.80)	9.87 (250.83)	10.00 (254.00)	15.25 (387.35)

Model	K	L	M	N	O	P	R	S
1M	7.25 (184.15)	1.25 (31.75)	0.69 (17.48)	6.37 (161.93)	8.12 (206.38)	3.50 (88.90)	3.50 (88.90)	4.62 (117.48)
2M	8.25 (209.55)	1.25 (31.75)	0.69 (17.48)	8.37 (212.73)	9.37 (238.13)	4.00 (101.60)	3.50 (88.90)	5.50 (139.70)
4M	8.75 (222.25)	1.25 (31.75)	0.69 (17.48)	9.00 (228.60)	10.00 (254.00)	4.00 (101.60)	4.00 (101.60)	6.12 (155.58)
8M	10.25 (260.35)	1.50 (38.10)	0.81 (20.65)	8.75 (222.25)	10.75 (273.05)	4.00 (101.60)	4.00 (101.60)	6.75 (171.45)
12M	11.87 (301.63)	1.50 (38.10)	1.06 (27.00)	9.12 (231.78)	11.37 (288.93)	4.50 (114.30)	4.50 (114.30)	7.50 (190.50)
18M	12.87 (327.03)	1.75 (44.45)	1.31 (33.35)	10.25 (260.35)	13.00 (330.20)	5.00 (127.00)	5.00 (127.00)	8.87 (225.43)
30M	14.75 (374.65)	1.75 (44.45)	1.31 (33.35)	12.75 (323.85)	15.50 (393.70)	5.50 (139.70)	5.50 (139.70)	10.00 (254.00)
42M	15.87 (403.23)	2.00 (50.80)	1.31 (33.35)	14.50 (368.30)	17.50 (444.50)	6.00 (152.40)	6.00 (152.40)	11.25 (285.75)
60M	16.75 (425.45)	2.00 (50.80)	1.31 (33.35)	16.00 (406.40)	19.00 (482.60)	6.00 (152.40)	6.00 (152.40)	12.25 (311.15)

Certified prints will be furnished for construction purposes after receipt of order.

* Shaft dia. +.0000/.0010, Coupling bore. -.0010/.0015

Marland Disconnect CEUHSD CECON Clutch

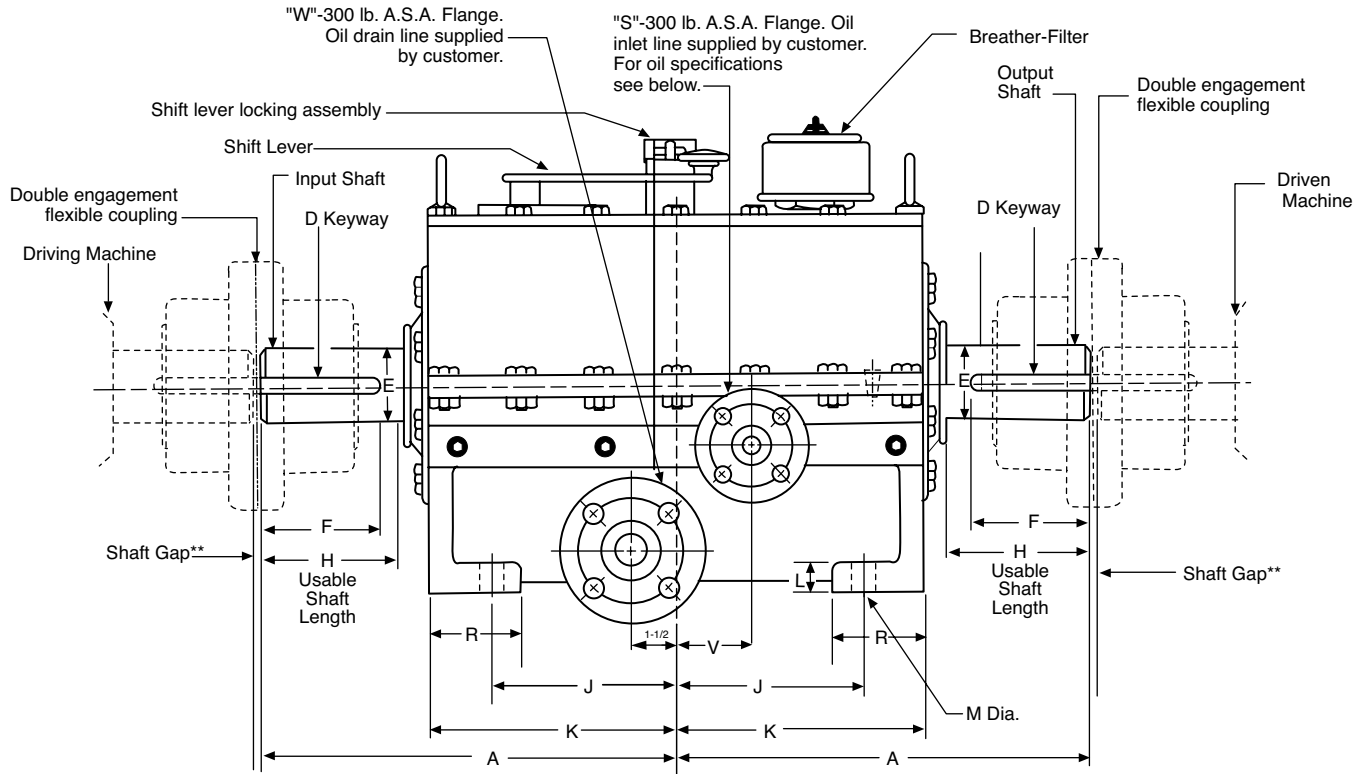

CECON Clutch CEUHSD Type	Rated Torque lb. ft.	Capacity HP Per 100 RPM	RPM Maximum ††	Oil Supply Gals. Per Min. †	Ship Weight lbs. (Less Cplgs.)
1M	1,000	19	12,000	2-1/2	250
2M	2,000	38	10,000	3-1/2	400
4M	4,000	76	8,000	4-1/2	700
8M	8,000	152	7,000	7	1,200
12M	12,000	229	6,000	9	1,700
18M	18,000	343	5,000	11	2,500
30M	30,000	571	4,500	14	3,200
42M	42,000	800	4,000	18	4,600
60M	60,000	1,143	3,500	23	6,100

Consult applicable local and national safety codes for proper guarding of rotating shafts and couplings.

** Shaft gap per coupling manufacturer or customer specification.

† To be supplied by customer: This quantity of regular turbine oil for approx. 150-250 S.S.U. at 100°F., at 15-20 P.S.I. pressure, at a max. inlet temp. of 110°F., filtered to 10-15 microns.

†† For higher speeds, consult factory

Marland Disconnect CEUHSD CECON Clutch

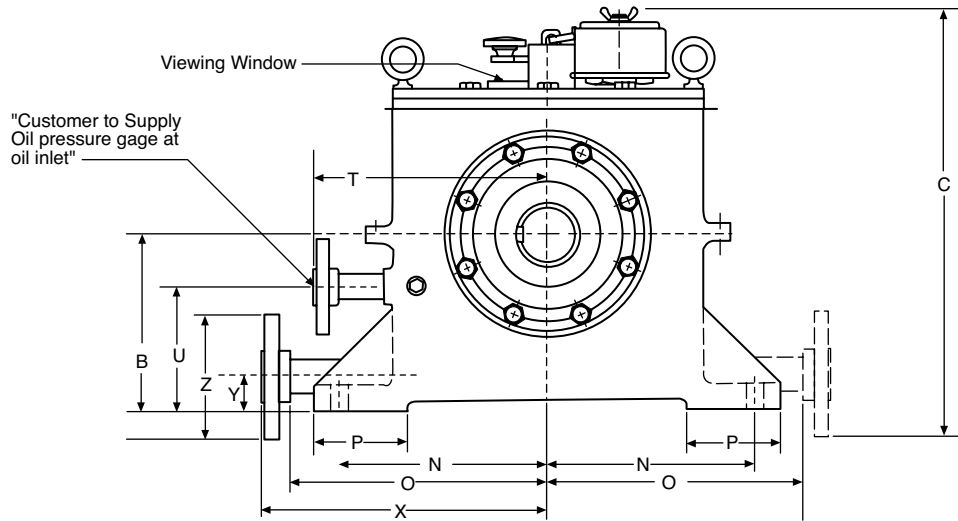

Dimensions inches (mm) – For Reference Only

Model	A	B	C	D	E*	F	H	J
1M	12.37 (314.33)	5.75 (146.05)	14.625 (371.48)	0.50 x 0.25 (12.70 x 6.35)	2.0000 (50.80)	3.75 (95.25)	3.87 (98.43)	6.37 (161.93)
2M	14.56 (369.90)	6.875 (174.63)	16.375 (415.93)	0.625 x 0.313 (15.88 x 7.95)	2.5000 (63.50)	4.50 (114.30)	4.62 (117.48)	7.37 (187.33)
4M	17.188 (436.58)	7.75 (196.85)	18.25 (463.55)	0.875 x 0.438 (22.23 x 11.13)	3.3125 (84.15)	5.25 (133.35)	5.37 (136.53)	7.75 (196.85)
8M	21.563 (547.70)	8.625 (219.08)	20.75 (527.05)	1.00 x 0.50 (25.40 x 12.70)	4.3125 (109.55)	6.75 (171.45)	6.94 (176.23)	11.50 (292.10)
12M	24.563 (623.90)	9.625 (244.48)	22.625 (574.68)	1.25 x 0.625 (31.75 x 15.88)	4.8125 (122.25)	7.50 (190.50)	7.69 (195.28)	12.75 (323.85)
18M	26.813 (681.05)	11.25 (285.75)	25.75 (654.05)	1.50 x 0.75 (38.10 x 19.05)	5.5625 (141.30)	8.44 (214.33)	8.62 (219.08)	14.00 (355.60)
30M	31.75 (806.45)	12.75 (323.85)	28.75 (730.25)	1.50 x 0.75 (38.10 x 19.05)	6.2500 (158.75)	10.37 (263.53)	10.62 (269.88)	16.50 (419.10)
42M	34.938 (887.43)	14.25 (361.95)	30.25 (768.35)	1.75 x 0.875 (44.45 x 22.23)	7.2500 (184.15)	11.56 (293.70)	11.81 (300.05)	18.25 (463.55)
60M	38.125 (968.38)	15.50 (393.70)	33.50 (850.90)	2.00 x 1.00 (50.80 x 25.40)	8.2500 (209.55)	12.62 (320.68)	12.87 (327.03)	20.25 (514.35)

Model	K	L	M	N	O	P	R	S
1M	7.69 (195.28)	1.00 (25.40)	.69 (17.48)	6.37 (161.93)	7.25 (184.15)	3.00 (76.20)	3.00 (76.20)	0.50 (12.70)
2M	9.12 (231.768)	1.00 (25.40)	.69 (17.48)	8.37 (212.73)	9.25 (234.95)	4.00 (101.60)	3.50 (88.90)	0.50 (12.70)
4M	10.94 (277.83)	1.25 (31.75)	.69 (17.48)	9.00 (228.60)	10.50 (266.70)	4.00 (101.60)	4.00 (101.60)	0.75 (19.05)
8M	13.69 (347.68)	1.25 (31.75)	.81 (20.65)	10.75 (273.05)	11.75 (298.45)	4.50 (114.30)	4.50 (114.30)	0.75 (19.05)
12M	15.37 (390.539)	1.50 (38.10)	.81 (20.65)	12.00 (304.80)	13.00 (330.20)	5.00 (127.00)	5.00 (127.00)	1.00 (25.40)
18M	16.69 (423.88)	1.50 (38.10)	1.06 (27.00)	13.75 (349.25)	15.00 (381.00)	5.50 (139.70)	5.50 (139.70)	1.00 (25.40)
30M	19.62 (498.48)	1.50 (38.10)	1.06 (27.00)	15.75 (400.05)	17.00 (431.80)	6.00 (152.40)	6.00 (152.40)	1.00 (25.40)
42M	21.62 (549.28)	1.50 (38.10)	1.31 (33.35)	17.00 (431.80)	18.50 (469.90)	6.50 (165.10)	6.50 (165.10)	1.25 (31.75)
60M	23.75 (603.25)	1.50 (38.10)	1.31 (33.35)	18.00 (457.20)	19.75 (501.65)	7.00 (177.80)	7.00 (177.80)	1.25 (31.75)

Model	T	U	V	W	X	Y	Z
1M	8.25 (209.55)	3.75 (95.25)	3.00 (76.20)	1.25(31.75)	9.25 (234.95)	1.37 (34.93)	5.25 (133.35)
2M	9.25 (234.95)	4.87 (123.83)	3.37 (85.73)	1.50(38.10)	11.25 (285.75)	1.50 (38.10)	6.12 (155.58)
4M	10.87 (276.23)	5.44 (138.10)	3.62 (92.08)	2.00(50.80)	12.50 (317.50)	1.75 (44.45)	6.50 (165.10)
8M	12.12 (307.98)	5.37 (136.53)	4.62 (117.48)	2.00(50.80)	13.75 (349.25)	1.75 (44.45)	6.50 (165.10)
12M	13.12 (333.38)	5.94 (150.83)	5.31 (134.95)	2.50(63.50)	16.00 (406.40)	2.25 (57.15)	7.50 (190.50)
18M	15.12 (384.18)	7.06 (179.40)	5.75 (146.05)	2.50(63.50)	18.00 (457.20)	2.25 (57.15)	7.50 (190.50)
30M	16.62 (422.28)	8.06 (204.80)	7.00 (177.80)	3.00(76.20)	20.00 (508.00)	2.50 (63.50)	8.25 (209.55)
42M	17.62 (447.68)	8.87 (225.43)	7.75 (196.85)	3.00(76.20)	21.50 (546.10)	2.50 (63.50)	8.25 (209.55)
60M	18.37 (466.73)	9.50 (241.30)	8.50 (215.90)	3.50(88.90)	22.75 (577.85)	3.00 (76.20)	9.00 (228.60)

Certified prints will be furnished for construction purposes after receipt of order.

* Shaft dia. +.0000/-.0010, Coupling bore -.0010/-.0015

Application Data Sheet



Fax: 877-216-3001

For Application Assistance Call: 1-800-216-3515

Date _____

Company Name _____

Address _____

City _____

Name of Contact _____

Title _____

Phone _____ Fax _____

Type of application

- Stand By Drive
- Dual Drive
- Creep Drive
- Kiln Drive
- Turning Gear

Maximum torque at clutch

_____ b. ft. (Nm)
_____ HP at _____ RPM

Power Source

- | | |
|--|--|
| <input type="checkbox"/> Electric Motor | <input type="checkbox"/> Diesel Engine |
| <input type="checkbox"/> Turbine | <input type="checkbox"/> Air Cylinder |
| <input type="checkbox"/> Hydraulic Motor | <input type="checkbox"/> Gas Engine |

Maximum Driving Speed _____ RPM

Maximum Overrunning Speed _____ RPM

Environment

Ambient Temperature Range, Lowest _____ F° (C°) Highest _____ F° (C°)

Exposed location? _____ Special Coating Required? _____

Mounting Configuration?

Shafts are in line, couplings required _____

Shaft orientation Horizontal _____ Vertical _____

Shafts are parallel, mounted on the CECON shaft a sheave _____ sprocket _____ other _____

Load Application

_____ Smooth _____ Moderate Shock _____ Shock

Service Life

Marland clutches and backstops are mechanical devices designed to protect mechanical equipment from rotation in the opposite direction and should generally not be considered Safety Devices. Marland clutches and backstops have surfaces which wear with use over time and as a result will need to be replaced. The clutches and backstops do not offer a feature for determining the time of their replacement. As a result the decision for time of replacement must be made by the operator of the equipment based upon the specific application and performance of the clutch or backstop.

Rotation Equipment

Rotation equipment is potentially dangerous and should be properly guarded. The user should check for all applicable safety codes (in local area) and provide a suitable guard. Marland backstops have surfaces which wear with use over time and as a result will need to be replaced. The decision for time of replacement must be made by the operator of the equipment base upon the specific application and performance of the clutch or backstop.

Catalog Changes

The contents of this catalog are subject to change without notice or obligation.

The Power Of One, The Strength Of Many.

OTHER PRODUCT SOLUTIONS FROM
ALTRA INDUSTRIAL MOTION

WWW.ALTRAMOTION.COM

Our comprehensive product offerings include various types of clutches and brakes, overrunning clutches, engineered bearing assemblies, gearing and gear motors along with linear products, belted drives, couplings and limit switches. With thousands of product solutions available, Altra provides true single source convenience while meeting specific customer requirements. Many major OEMs and end users prefer Altra products as their No. 1 choice for performance and reliability.



ELECTRIC CLUTCHES AND BRAKES

Inertia Dynamics
Matrix
Stromag
Warner Electric



HEAVY DUTY CLUTCHES AND BRAKES

Industrial Clutch
Stromag
Svendborg Brakes
Twiflex
Wichita Clutch



OVERRUNNING CLUTCHES

Formsprag Clutch
Marland Clutch
Stieber



ENGINEERED COUPLINGS AND UNIVERSAL JOINTS

Ameridrives
Bibby Turboflex
Guardian Couplings
Huco
Lamiflex Couplings
Stromag
TB Wood's



GEAR DRIVES

Bauer Gear Motor
Boston Gear
Delroyd Worm Gear
Nuttall Gear



GEAR MOTORS

Bauer Gear Motor



POWER TRANSMISSION COMPONENTS

LINEAR ACTUATORS AND CONTROLS

Warner Linear



ENGINEERED BEARING ASSEMBLIES

Kilian



AIR MOTORS

Huco



BELTED DRIVES AND SHEAVES

TB Wood's



GEARED CAM LIMIT SWITCHES

Stromag

Marland Clutch Facilities

North America

USA

23601 Hoover Road
Warren, MI 48089 - USA
1-800-216-3515

*Roller Ramp and Sprag Type
Overrunning Clutches
and Backstops*

Europe

Germany

Hatschekstraße 36
69126 Heidelberg - Germany
+49 (0) 6221-30470

*Overrunning Clutches
and Holdbacks*

Asia Pacific

Australia

+61 2 9894 0133

China

+86 21 5169-9255

Hong Kong

+852 2615 9313

Singapore

+65 6487 4464

Taiwan

+886 2 2577 8156

Thailand

+66 2322 5527

The Brands of Altra Industrial Motion

Couplings

Ameridrives

www.ameridrives.com

Bibby Turboflex

www.bibbyturboflex.com

Guardian Couplings

www.guardiancouplings.com

Huco

www.huco.com

Lamiflex Couplings

www.lamiflexcouplings.com

Stromag

www.stromag.com

TB Wood's

www.tbwoods.com

G geared Cam Limit Switches

Stromag

www.stromag.com

Electric Clutches & Brakes

Inertia Dynamics

www.idicb.com

Matrix

www.matrix-international.com

Stromag

www.stromag.com

Warner Electric

www.warnerelectric.com

Linear Products

Warner Linear

www.warnerlinear.com

Engineered Bearing Assemblies

Kilian

www.kilianbearings.com

Heavy Duty Clutches & Brakes

Industrial Clutch

www.indclutch.com

Twiflex

www.twiflex.com

Stromag

www.stromag.com

Svendborg Brakes

www.svendborg-brakes.com

Wichita Clutch

www.wichitaclutch.com

Belted Drives

TB Wood's

www.tbwoods.com

Gearing

Bauer Gear Motor

www.bauergears.com

Boston Gear

www.bostongear.com

Delroyd Worm Gear

www.delroyd.com

Nuttall Gear

www.nuttallgear.com

Overrunning Clutches

Formsprag Clutch

www.formsprag.com

Marland Clutch

www.marland.com

Stieber

www.stieberclutch.com

Neither the accuracy nor completeness of the information contained in this publication is guaranteed by the company and may be subject to change in its sole discretion. The operating and performance characteristics of these products may vary depending on the application, installation, operating conditions and environmental factors. The company's terms and conditions of sale can be viewed at <http://www.altramotion.com/terms-and-conditions/sales-terms-and-conditions>. These terms and conditions apply to any person who may buy, acquire or use a product referred to herein, including any person who buys from a licensed distributor of these branded products.

©2018 by Marland Clutch LLC. All rights reserved. All trademarks in this publication are the sole and exclusive property of Marland Clutch LLC or one of its affiliated companies.