

Sprag Clutches

Indexing, Backstopping & Overrunning Models



Table of Contents

General..... 2

Typical Applications 3

Design Advantages..... 4

RM Engineering Data..... 5

RM Dimensional Data 6

Freewheel Clutch Interchange Chart 7

RM Clutch Accessories-TA/EC 8

CA/CC Clutch Couplings 9

RSCI Models 10

CSK Models 11

AS Models..... 12

FSR Models..... 13

Marland Freewheel Clutches

General

Marland Clutch has been producing overrunning clutches since 1931. Primary Marland products are backstops, clutches and clutch couplings based on their one-way clutch design that utilizes the principle of cylindrical rollers on inclined cam planes.

Marland Clutch also brings to the North American market a line of proven sprag type freewheel clutches. Marland utilizes the knowledge of its sister divisions, Stieber® of Germany and Formsprag® of the United States, to manufacture world class high performance sprag clutches in the United States.

Marland Freewheels are a combination of German knowledge and American manufacturing ingenuity. Simply put, the Marland freewheel consists of an inner race, an outer race and a set of sprags between the inner and outer races. Each sprag is nothing more than a wedge-piece that allows free rotation of the inner race when rotated in the counterclockwise direction. (See illustration below). When the inner race is rotated in the clockwise direction, the sprags, through a wedging action, transmit torque from the inner race to the outer race. The opposite is true of the outer race. Clockwise rotation of the outer race in motion; counterclockwise rotation results in torque transmission from the outer race to the inner race.

The sprag elements in the Marland freewheel clutches result from years of design and development by Stieber and Formsprag.

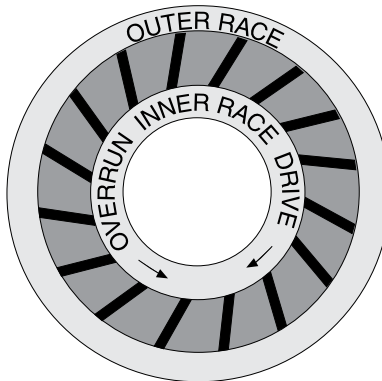

Design Benefits

Maximum Torque in Minimum Space

The sprags lie in close proximity to each other permitting more sprags for increased torque capacity.

Long Life

Ultra-hard sprags provide extra-long life, maximum wear resistance and lower maintenance costs.

Repeatability

Springs exert a small amount of rotary pressure on each sprag to ensure that the freewheel engages without backlash.

Adaptability

Marland can supply modifications quickly to meet your specific needs.

Products shown in this catalog are covered by numerous U.S. and Foreign patents. For further information and installation procedures, contact Marland Clutch.

Typical Applications

Here are three basic types of applications for overrunning clutches: freewheeling, indexing and backstopping. Marland Clutch can provide a freewheel for any application requirement.

Freewheeling

Any time there is a difference in speed between the inner race and outer race, a freewheel or overrunning condition exists. Examples of freewheeling applications are compound drives, two speed drives, starter drives, drives with high inertia loads, idler drives, standby drives, etc.

High Inertia Drive

When the drive is started, the clutch engages automatically and rotates the high inertia load. When the drive is shut down, the drive can stop, saving wear and tear on the drive components. The high inertia load continues to rotate because the clutch allows it to freewheel or overrun harmlessly.

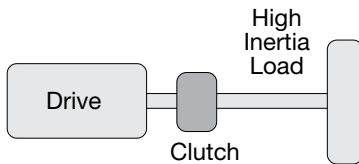

Starter Drive

The clutch automatically engages as the starter motor cranks the diesel. As the diesel starts and increases speed, the clutch overruns on the diesel side and freewheels as power is removed from the starter drive.

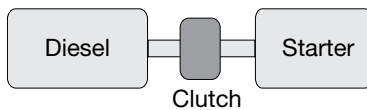

Two Speed Drives

When the 900 RPM motor is running, the freewheel clutch automatically engages and drives the load at 900 RPM while the clutch freewheels on the 1,800 RPM motor side of the load. When the 900 RPM motor is turned off, the clutch automatically goes into the freewheel mode. The opposite occurs when the 1,800 RPM motor is started.

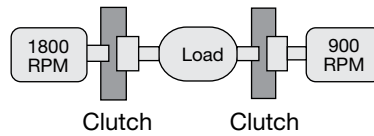

Indexing

When a reciprocating motion is applied to a driving race, the driven race motion will result in a unidirectional intermittent motion. This is an indexing action.

Packaging Conveyor

When the bell crank rotates, the indexing lever moves back and forth. The positive engagement of the sprags in the clutch results in positive linear motion control.

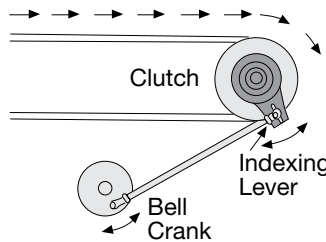

Backstopping

When one race is fixed to a stationary member, the other race can rotate in only one direction. In this configuration, the clutch is used as a backstop. Backstops are used to prevent incorrect machine rotation, protecting machinery, goods and personnel from harm. Backstops are typically used on inclined conveyors, compressors, pumps, speed reducers, blowers, etc.

Inclined Conveyor

In this application, the outer race is secured to the conveyor arm. The inner race is free to rotate in the clockwise direction. If the conveyor tries to reverse direction, the clutch will engage and prevent backward movement.

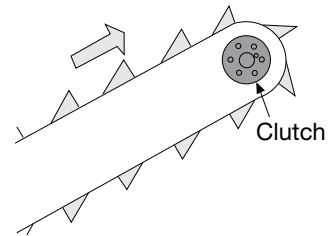

Blower Application

A clutch has its outer race secured. The blower motor can rotate the blower in one direction while the clutch is freewheeling. When the blower drive is turned off, reverse direction of the blower (windmilling) is prevented by the automatic engagement of the sprags.

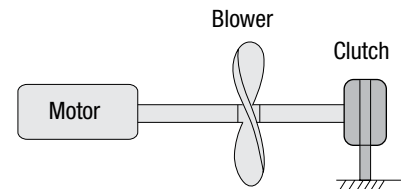

General

Models **RMS**, **RMT** and **RMI**

This group of complete freewheels with ball bearings and seals have three types – **RMS**, **RMT** and **RMI**.

The **RMS** model freewheel is a general purpose clutch used for overrunning, backstopping and indexing applications. This series has chromium-carbide surface sprags. The result is a sprag with extra-long life, maximum wear resistance and lower maintenance costs. They are available with oil or grease lubrication and are sized to match all of the brands on the market.

The **RMI** model freewheels feature the use of centrifugal throwout sprags. These sprags will “lift-off” the inner race during high-speed outer race overrunning.

The **RMT** models are used for applications that require high outer race overrunning speeds and low driving speeds.

In this design, the mass of the sprag is located so that when the outer race is overrunning, the centrifugal force of the sprags overcomes the force of the energizing springs causing the sprags to completely “lift-off” of the inner race as shown below.

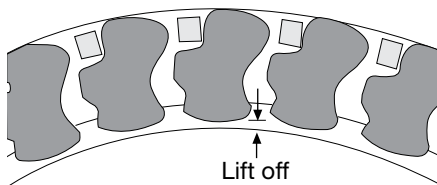

The **RMI** model freewheels also feature the use of centrifugal throwout sprags except they are designed to “lift-off” of the outer race during high-speed inner race overrunning. In this design, the mass of the sprag is located so that when the inner race is overrunning the centrifugal force of the sprags overcomes the force of the energizing springs causing the sprags to completely “pull away” from the outer race.

Torque transmission

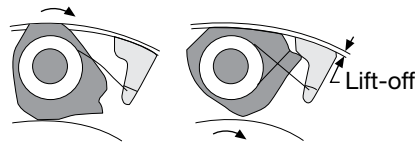

The **RMI** models are used for applications that require low driving speeds and a high speed overrunning inner race. They are excellent for use as backstops by mounting the freewheel’s inner race onto the shaft and attaching or anchoring the freewheel’s outer race via a torque arm to a fixed position. This makes for a simple, space saving installation that can be retrofitted in the field.

In the **RMT** and **RMI** models, the point at which the sprags “lift-off” of the outer or inner race is listed as the “lift-off speed.” The maximum drive speed is always less than the lift-off speed to insure positive engagement during driving use. The primary advantage of the **RMT** and **RMI** lift-off designs is less wear of the sprags and races, making the life of the clutch only limited by the life of the bearings.

Oil Lubricated Designs

The **RMS** and **RMT** are both available in oil lubricated configurations. Standard lip type oil seals and open bearings are employed to provide maximum protection and the best possible oil circulation.

Grease Lubricated Designs

The **RMS_FG** models are general-duty clutches for freewheeling, backstopping and indexing applications. They are suitable for vertical applications and high speed overrunning applications where high speed driving also occurs. The clutch utilizes standard lip type seals and open bearings and is supplied packed with a high quality NLGI Grade 1 Grease.

Sealed Bearing Design

The **RMI_SB** models are designed for high speed inner race overrunning applications. The non-contact sealed for life bearings and the “lift-off” design provide for maintenance free operation and cooler operating temperatures. This clutch is not re-greasable.

High Performance Design

The **RMI_HP** models are designed for high speed inner race overrunning applications where harsh environmental conditions exist. This design incorporates a labyrinth seal arrangement in conjunction with a non-contact seal greased for life bearing. A quantity of grease is provided between the seal and the bearing as an extra measure to keep out contaminants.

Engineering Date Models RMS, RMT, RMI

Model	Maximum Torque Capacity lb. ft.	Maximum Bore in.	Lubrication Type	Overrunning Inner Race RPMs	Maximum RPMs Overrunning Outer Race RPMs	Lift Off RPMs	Maximum Driving RPMs	Standard Bore and Keyway Sizes ** in.
RMS 12 FG	275	.750	Grease	3,000	900	NA	-	.500-1/8 x 1/16 .625, .750 - 3/16 x 3/32
RMS 12	275	.750	Oil	3,000	900	NA	-	
RMS 14 FG	300	.875	Grease	2,800	850	NA	-	.500 - 1/8 x 1/16 .625, .750 - 3/16 x 3/32 .875 - 3/16 x 1/16
RMS 14	300	.875	Oil	2,800	850	NA	-	
RMT 14	300	.875	Oil	2,800	5,000	1,300	1,100	
RMI 14 SB	Consult Factory							
RMI 14 HP	Consult Factory							
RMS 21 FG	1,175	1.312	Grease	2,500	800	NA	-	.875 - 3/16 x 3/32 1.00, 1.125, 1.25 - 1/4 x 1/8 1.312 - 1/4 x 3/32
RMS 21	1,175	1.312	Oil	2,500	800	NA	-	
RMT 21	1,175	1.312	Oil	2,500	4,000	1,200	1,000	
RMI 21 SB	575	1.312	None	4,000	NA	730	330	
RMI 21 HP	575	1.312	None	4,000	NA	730	330	
RMS 26 FG	1,550	1.625	Grease	1,175	800	NA	-	
RMS 26	1,550	1.625	Oil	1,175	800	NA	-	
RMI 26 SB	950	1.625	None	4,000	NA	580	230	
RMI 26 HP	950	1.625	None	4,000	NA	580	230	
RMS 32 FG	2,250	2.00	Grease	2,200	750	NA	-	1.250 - 1/4 x 1/8 1.375, 1.437, 1.50, 1.625, 1.688, 1.75 - 3/8 x 3/16 1.937, 2.00 - 3/8 x 1/8
RMS 32	2,250	2.00	Oil	2,200	750	NA	-	
RMT 32	2,250	2.00	Oil	2,200	3,600	1,200	1,000	
RMI 32 SB	1,260	2.00	None	4,000	NA	590	240	
RMI 32 HP	1,260	1.625	None	4,000	NA	590	240	
RMS 40 FG	2,375	2.50	Grease	900	600	NA	-	
RMS 40	2,375	2.50	Oil	900	600	NA	-	
RMI 40 SB	2,065	2.50	None	4,000	NA	510	250	
RMI 40 HP	2,065	2.00	None	4,000	NA	510	250	
RMS 47 FG	5,000	2.937	Grease	1,600	450	NA	-	1.937, 2.00, 2.25 - 1/2 x 1/4 2.437, 2.50 - 5/8 x 5/16 2.750 - 5/8 x 7/32 2.937 - 5/8 x 1/8
RMS 47	5,000	2.937	Oil	1,600	450	NA	-	
RMT 47	5,000	2.937	Oil	1,600	2,500	1,000	800	
RMI 47 SB	4,500	2.937	None	3,600	NA	480	210	
RMI 47 HP	4,500	2.50	None	3,600	NA	480	210	
RMS 55 FG	7,000	3.437	Grease	1,000	650	NA	-	
RMS 55	7,000	3.437	Oil	1,000	650	NA	-	
RMT 55	7,000	3.437	Oil	1,000	1,800	800	650	
RMI 55 SB	6,650	3.437	None	2,400	NA	460	190	
RMS 72 FG	13,000	4.437	Grease	850	525	NA	-	3.00, 3.25 - 3/4 x 3/8 3.437, 3.50, 3.75 - 7/8 x 7/16 3.937, 4.000 - 1 x 1/2 4.250 - 1 x 3/8 4.437 - 1 x 1/4
RMS 72	13,000	4.437	Oil	850	525	NA	-	
RMT 72	13,000	4.437	Oil	850	1,500	675	525	
RMI 72 SB	15,490	4.437	None	1,800	NA	455	200	
RMS 87 FG	18,000	5.437	Grease	700	500	NA	-	
RMS 87	18,000	5.437	Oil	700	500	NA	-	
RMT 87	18,000	5.437	Oil	700	1,350	650	500	
RMI 87 SB	Consult Factory							
RMS 112 FG	27,000	7.00	Grease	700	375	NA	-	4.937, 6.00 - 1-1/4 x 5/8 6.25, 6.625, 6.75 - 1-1/2 x 1/2 7.000 - 1-1/2 x 7/16
RMS 112	27,000	7.00	Oil	500	375	NA	-	
RMT 112	27,000	7.00	Oil	500	1,100	475	375	
RMI 112 SB	Consult Factory							

Nomenclature:

- RMS = Standard (no lift-off)
- RMS_FG = Standard, Full of Grease, purgeable and re-greaseable
- RMT = Lift-off type – outer race overrunning
- RMI_SB = Lift-off type – inner race overrunning with Sealed Bearing no maintenance design
- RMI_HP = Lift-off type – inner overrunning with High Performance, sealed bearing and labyrinth seals.

Notes:

Do not use slippery additives, such as Molybdenum Disulfide or Graphite. RMS_FG grease lubricated clutches should be flushed and filled every 2 to 6 months depending on the severity of the application. Fill units with a high quality NLGI Grade 1 grease, such as Lubriplate AERO or Mobilux 5. All RMI clutches are **not regreaseable**. They are “no maintenance” clutches. **Adding grease or oil to an RMI clutch can lead to failure.**

** Custom and metric bores are available upon request.

Dimensional Data Models RMS, RMT, RMI

Marland complete freewheel clutches, models RMS, RMT and RMI are manufactured in the United States. These three types serve different fields of applications:

The RMS model freewheels are general purpose clutches used for overrunning, backstopping and indexing applications.

The RMT model freewheels feature the use of centrifugal “lift-off” sprags. These sprags will lift-off of the inner race during high-speed outer race overrunning. The RMT model is ideal for high outer race overrunning speeds and low driving speeds.

The RMI model freewheels feature the use of centrifugal “lift-off” sprags. These sprags will lift-off of the outer race during high speed overrunning. The RMI model is ideal for high inner race overrunning speeds and low driving speeds.

Both the RMT and the RMI models can contribute to longer life of your clutch due to their “lift-off” sprag design.

The RMS, RMT and RMI model freewheels include ball bearings. These self-contained freewheels can carry radial loads. Pulleys, gears and torque arms can be mounted directly to the outer race.

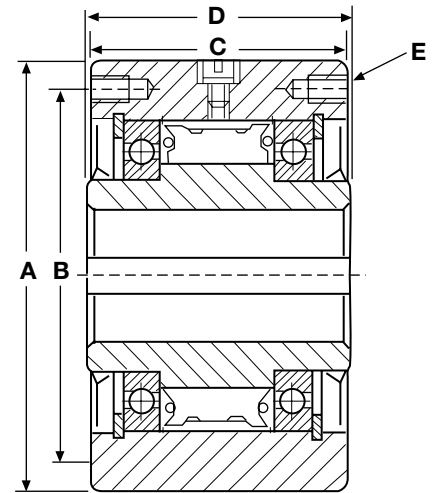

RMS RMT RMI Size	Maximum Bore in./mm	A Outside Diameter in./mm	B Bolt Circle in./mm	C Outer Race Length in./mm	D Overall Length in./ mm	E Quantity & Thread Size of Holes	Approximate Weight lbs./kg
12	.750/19.05	$\frac{3.000}{2.998}$ $\frac{76.20}{76.15}$	2.625/66.67	2.375/60.45	2.500/63.50	4-.250-28	3.5/1.6
14	.875/22.22	$\frac{3.500}{3.498}$ $\frac{88.90}{88.85}$	2.875/73.02	2.687/68.25	2.750/69.85	4-.312-24	6/2.7
21	1.312/33.32	$\frac{4.250}{4.248}$ $\frac{107.95}{107.90}$	3.625/92.08	3.375/85.72	3.500/88.90	4-.312-24	10/4.5
26	1.625/41.27	$\frac{4.750}{4.748}$ $\frac{120.65}{120.60}$	4.250/107.95	3.125/79.38	3.250/82.55	6-.312-24	12/5.4
32	2.000/50.80	$\frac{5.375}{5.373}$ $\frac{136.52}{136.47}$	4.750/120.65	3.625/92.08	3.750/95.25	6-.312-24	19/8.6
40	2.500/63.50	$\frac{6.500}{6.498}$ $\frac{165.10}{165.05}$	5.750/146.05	3.375/85.72	3.500/88.90	8-.375-24	24/10.9
47 ¹	2.937/74.60	$\frac{7.125}{7.123}$ $\frac{180.98}{180.92}$	6.250/157.75	4.875/123.82	5.000/127.00	8 ¹ -.75-24	42/19.0
55 ¹	3.437/87.30	$\frac{8.750}{8.748}$ $\frac{222.25}{222.20}$	7.000/177.80	5.875/149.22	6.000/152.40	8 ¹ -.500-20	83/37.6
72	4.437/112.70	$\frac{10.000}{9.998}$ $\frac{254.00}{253.95}$	8.937/227.00	5.875/149.22	6.00/152.40	8-.500-20	102/46.2
87	5.437/138.10	$\frac{12.000}{11.997}$ $\frac{304.80}{304.72}$	9.750/247.65	6.250/158.75	6.380/161.9	10-.625-18	156/171
112	7.000/177.80	$\frac{15.000}{14.977}$ $\frac{381.00}{380.92}$	11.75/298.45	6.50/165.10	6.630/168.3	12-.625-18	250/113

Notes

- ¹ Six holes are equally spaced 60° with two additional holes located 30° to the six equally spaced holes and 180° apart. Six hardened mounting screws are adequate for loads up to 3,000 lb. ft. for size 47 and 5,100 lb. ft. for size 55. Use eight hardened mounting screws for higher loads. SAE Grade 5 bolts should be used for all models.

Interchange Chart

The interchange chart shows the Marland freewheel clutch that is dimensionally interchangeable. Torque capacities, maximum speeds and lift-off speeds may differ. Please see page 6 for complete specifications.

Marland		Formsprag		Morse		Ringspann	
Unit	Maximum Torque lb. ft.	Unit	Maximum Torque lb. ft.	Unit	Maximum Torque lb.ft.	Unit	Maximum Torque lb. ft.
RMS-12	275	FSO & HPI 300	275	MG, MI & MO 300A	275	NA	NA
RMS-14	300	FSO & HPI 400	300	MG, MI & MO 400A	400	RMS-14	340
RMS-21	1,175	FSO & HPI 500	1,175	MG, MI & MO 500A	1,175	RMS-21	1,130
RMS-26	1,550	NA	NA	NA	NA	RMS-26	1,885
RMS-32	2,250	FSO & HPI 600	2,250	MG, MI & MO 600A	2,250	RMS-32	2,325
RMS-40	2,375	NA	NA	NA	NA	RMS-40	3,200
RMS-47	5,000	FSO & HPI 700	5,000	MG, MI & MO 700A	5,000	RMS-47	6,800
RMS-55	7,000	FSO & HPI 750	7,000	MG, MI & MO 750	7,000	RMS-55	10,400
RMS-72	13,000	FSO & HPI 800	13,000	MG, MI & MO 800	13,000	RMS-72	14,500
RMS-87	18,000	FSO & HPI 900	18,000	MG, MI & MO 900	18,000	NA	NA
RMS-112	27,000	FSO & HPI 1027	27,000	MG, MI & MO 1000	25,000	NA	NA
RMT-14	300	C/T-400	300	MR-400A	400	RMZ-14	230
RMT-21	1,175	C/T-500	1,175	MR-500A	1,175	RMZ-21	600
RMT-32	2,250	C/T-600	2,250	MR-600A	2,250	RMS-32	2,160
RMT-47	5,000	C/T-700	5,000	MR-700	5,000	RMZ-47	6,275
RMT-55	7,000	C/T-750	7,000	MR-750	7,000	RMZ-55	9,900
RMT-72	13,000	C/T-800	13,000	MR-800	13,000	RMZ-72	12,000
RMT-87	18,000	C/T-900	18,000	MR-900	18,000	NA	NA
RMT-112	27,000	C/T-1027	27,000	MR-1000	25,000	NA	NA

Marland	Formsprag	Morse	GMN	Ringspann
CSK-8	CSK-8	NA	NA	778
CSK-12	CSK-12	NA	NA	ZZ6201
CSK-15	CSK-15	NA	NA	ZZ6202M
CSK-17	CSK-17	KK-17	FK-6203	ZZ6203M
CSK-20	CSK-20	KK-20	FK-6204	ZZ6204M
CSK-25	CSK-25	KK-25	FK-6205	ZZ62025M
CSK-30	CSK-30	KK-30	FK-6206	ZZ6026S
CSK-35	CSK-35	KK-35	NA	ZZ6207
CSK-40	CSK-40	NA	NA	ZZ40
AS-6	AS-6	NSS-6	NA	NA
AS-8	AS-8	NSS-8	NA	NA
AS-10	AS-10	NSS-10	NA	NA
AS-12	AS-12	NSS-12	NA	NA
AS-15	AS-15	NSS-15	NA	NA
AS-20	AS-20	NSS-20	NA	FCN 20K
AS-25	AS-25	NSS-25	NA	FCN 25K
AS-30	AS-30	NSS-30	NA	FCN 30K
AS-35	AS-35	NSS-35	NA	FCN 35CF
AS-40	AS-40	NSS-40	NA	FCN 40CF
AS-45	AS-45	NSS-45	NA	FCN 45CF
AS-50	AS-50	NSS-50	NA	FCN 50CF
AS-55	AS-55	NA	NA	FCN 55CF
AS-60	AS-60	NSS-60	NA	FCN 60CF
AS-80	AS-80	NA	NA	NA

Marland	Morse
R 204	B-204A
R 205	B-205A
R 206	B-206A
R 207	B-207A
R 208	B-208A
R 210	B-210A

Torque Arms

The TA torque arms are made specifically for use with the Marland RM_ model freewheel clutches. The use of the TA torque arms will help facilitate the installation of the clutch when used as a backstop.

The torque arms are available with any Marland RM_ model size 14 through 112. The TA torque arms come predrilled and ready for installation.

Installation

The torque arm must not be rigidly anchored. Rotation must be restricted by either a pin or an angle iron bracket. The torque arm must be free to move axially to prevent damage to the bearings in the clutch. When a pin is used, the diameter of the pin must be 1/32 of an inch smaller than the pin hole (F) in the torque arm. A threaded pin should not be used.

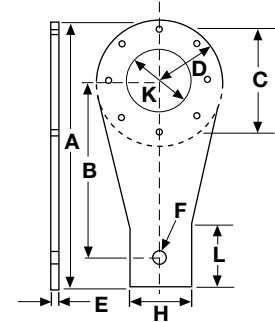

Torque Arm Dimension Table (inches)

Model	A	B	C	D	E	F	H	K	L	No. of Holes
TA 14	8.625	6.250	2.875	1.875	.375	.53125	2	1.625	1	8
TA 21	9	6.250	3.625	2.125	.375	.53125	2	2	1.125	8
TA 26	10.125	7	4.250	2.500	.375	.78125	2.250	2.4375	1.375	12
TA 32	11.500	8	4.750	2.8125	.375	.78125	2.500	2.8125	1.500	12
TA 40	13.625	9.500	5.750	3.250	.375	.78125	3	3.4375	1.750	16
TA 47	15	10.500	6.250	3.5625	.500	1.3125	3	4	2	12
TA 55	18.375	12.875	7	4.375	.500	1.28125	3.750	4.375	2.375	12
TA 72	21	14.625	8.9375	5	.500	1.53125	4	5.750	2.750	16
TA 87	Consult Factory									
TA 112	Consult Factory									

End Covers

The EC end covers are made specifically for use with Marland RM_ model overrunning clutches from 12 gauge mild steel.

The use of the EC end cover will protect personnel from coming into contact with rotating shafts.

The end covers are available with any Marland RM_ model size 14 through 112. The EC end covers come predrilled and ready for installation.

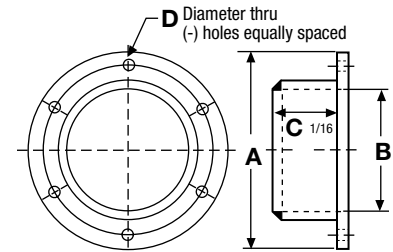

End Cover Dimension Table (inches)

Model	A	B	C	D	No. of Holes	Dia. Bolt Circle
EC 14	3.500	1.500	2.125	.341	4	2.875
EC 21	4.250	1.875	3.125	.341	4	3.625
EC 26	4.750	2.250	3.125	.341	6	4.250
EC 32	5.375	2.750	3.125	.341	6	4.750
EC 40	6.500	3.250	4.125	.403	8	5.750
EC 47	7.125	3.875	4.125	.403	6	6.250
EC 55	8.750	4.250	5.125	.527	6	7
EC 72	10	5.625	5.625	.527	8	8.937
EC 87	Consult Factory					
EC 112	Consult Factory					

CA/CC Clutch Coupling Packages

Clutch couplings are used in applications that require the coupling of two in-line shafts, such as between a reducer and a pinion stand. The clutch should always be mounted on the low temperature shaft in any application. These clutch couplings may use the RMS, RMT or RMI type

clutch depending on what the application requires. Refer to Page 5 for a description of the RM_ model clutches. The CA model allows for the removal of the clutch, adapter and coupling without moving the connected equipment, unlike the CC models which does require moving them.

The clutch bore (see Page 7 for maximum available clutch bores), coupling bore and distance required between the shafts must be specified when ordering.

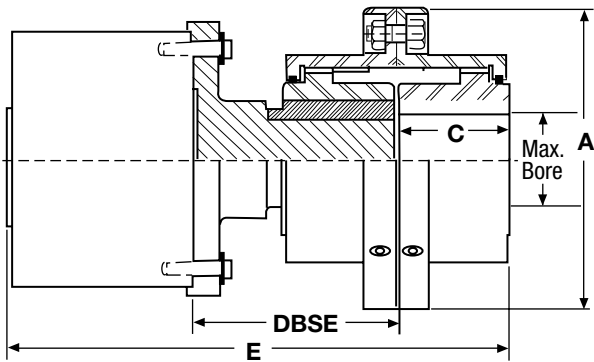

CA Model

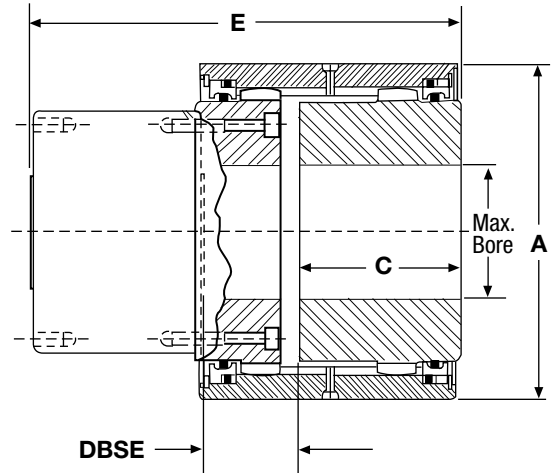

CC Model

Package Model Number	Clutch Model	Coupling Model	Max. Coupling Bore (inches)	Max. Clutch Bore (inches)	A Major Diameter (inches)	C Bore Length (inches)	E Overall Length (inches)	DBSE (inches)
RM_14 CA12	RM_14	F201 1/4	1.75	.875	4.00	1.69	8.97	4.53
RM_14 CC20	RM_14	C202	2.88	.875	5.38	2.44	6.71	1.53
RM_21 CA15	RM_21	F201 1/2	2.38	1.312	6	1.94	10.75	5.31
RM_21 CC25	RM_21	C202 1/2	3.75	1.312	6.50	3.03	8.20	1.69
RM_26 CA20	RM_26	F202	2.88	1.625	7	2.44	11.50	5.81
RM_26 CC30	RM_26	C203	4.25	1.625	7.44	3.59	8.89	2.03
RM_32 CA20	RM_32	F202	2.88	2	7	2.44	12	5.81
RM_32 CC30	RM_32	C203	4.25	2	7.44	3.59	9.39	2.03
RM_40 CA25	RM_40	F202 1/2	3.75	2.50	8.38	3.30	12.41	5.88
RM_40 CC40	RM_40	C204	5.88	2.50	9.86	4.75	10.56	2.31
RM_47 CA30	RM_47	F203	4.25	2.937	9.44	3.59	16.25	7.66
RM_47 CC40	RM_47	C204	5.88	2.937	9.86	4.75	12.06	2.31
RM_55 CA35	RM_55	F203 1/2	4.75	3.347	11	4.19	19	8.81
RM_55 CC45	RM_55	C204 1/2	6.75	3.347	10.88	5.05	13.70	2.63
RM_72 CA40	RM_72	F204	5.88	4.437	12.50	4.75	20.44	9.69
RM_72 CC55	RM_72	C205 1/2	7.62	4.437	12.75	5.52	14.48	2.97

Model RSCI Internal Backstops

The Long Life High Speed Backstop

The best solution for high speed backstop applications is a backstop in which the locking elements do not wear while the device is rotating. This will result in a long dependable life.

The backstop should also be designed so that its outer race is the stationary element and the inner race does all the overrunning or freewheeling. This permits an easy, low cost installation.

Marland Clutch has the ideal high-speed backstop.

RSCI models feature a sprag backstop that is made for an overrunning inner race and has sprags that lift-off of the outer race at high speeds. The **RSCI** models are designed to be built into your equipment on the high-speed or intermediate speed shaft where the torque is the lowest.

The **RSCI** "lift-off" design eliminates the constant rubbing and wearing of the sprags when the backstop device is freewheeling. The **RSCI** model's design makes them simple to apply to your equipment. The inner race is put on the shaft and the outer race is fixed to the housing.

This means a space and cost savings over backstops that are mounted on the outside of your equipment.

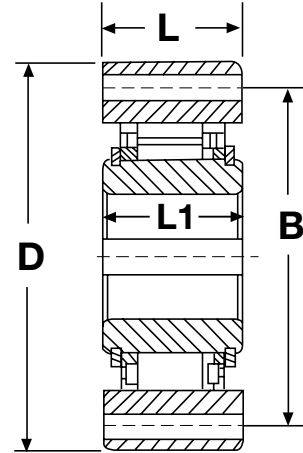

RSCI Model	**Bore Size mm (H7)	"B" mm	"D" mm (h6)	"L1" mm	"L" mm	Max Torque lb. ft.	***Lift-Off Speed RPM	Number of Holes	*Bolt Size mm
20	20	78	90	35	35	156	875	6	M6
25	25	82	95	35	35	235	825	6	M6
30	30	87	100	35	35	277	780	6	M6
35	35	96	110	35	35	406	740	8	M6
40	40	108	125	35	35	590	720	8	M8
45	45	112	130	35	35	673	665	8	M8
50	50	132	150	40	40	1,033	610	8	M8
60	60	155	175	60	50	1,734	490	12	M10
70	70	165	190	60	50	2,250	480	12	M10
80	80	185	210	70	60	3,321	450	12	M10
90	90	206	230	80	70	3,595	420	12	M12
100	100	258	290	90	80	7,749	455	12	M16
130	130	278	322	90	80	11,623	415	12	M16
180	180	360	412	90	80	23,247	365	12	M20

* Clearance mounting holes for listed bolt sizes

** Keyseats to DIN 6885.1

*** Max. Driving speed should be limited to .4* lift-off speed.

Marland CSK Freewheel Clutches

The **CSK** model freewheel is a sprag type clutch integrated into a 6200 series ball bearing (except sizes 8 and 40). It provides you with a one way clutch, and eliminates the need for a ball bearing. It gives a high degree of freewheeling accuracy while utilizing a minimum of space.

The **CSK** model freewheels can be used in backstopping, overrunning or indexing applications.

The **CSK** model freewheels are available with bores to 1.57" (40mm) and torque ratings to 384 lb. ft. They are supplied filled with grease and are maintenance free.

The torque is transmitted on the inner and outer race by an interference fit into a rigid housing and onto a shaft. The tolerance for the housing fit is N6 and the tolerance for the shaft is n6.

Operating temperature range: -40° F (-40° C) to 212° F (+100° C).



Model	Bore* d ^{H7} in./mm	Torque lb. ft.	Max. Overrunning Speed RPM	Width L in./mm	O.D. D ₆ in./mm	Bearing Loads	
						Dynamic lb.	Static lb.
CSK 8	.31/8	2.6	15,000	.35/9	.87/22	738	193.5
CSK 12	.47/12	8.8	10,000	.39/10	1.26/32	1372.5	623.25
CSK 15	.59/15	14.7	8,400	.43/11	1.38/35	1665	769.5
CSK 17	.67/17	30	7,350	.47/12	1.57/40	1777.5	855
CSK 20	.79/20	50	6,000	.55/14	1.85/47	2115	1003.5
CSK 25	.98/25	77	5,200	.59/15	2.05/52	2407.5	1228.5
CSK 30	1.18/30	133	4,200	.63/16	2.44/62	2632.5	1451.25
CSK 35	1.38/35	177	3,600	.67/17	2.83/72	2835	1638
CSK 40	1.57/40	284	3,000	.87/22	3.15/80	3496.5	2756.25

Model AS Freewheel Clutches

The **AS** model freewheel clutch is a ramp & roller type clutch, non-bearing supported. They are designed to be built into a customer's product for use as overrunning, indexing and backstopping clutches.

Bearings are required to support axial and radial loads. Lubrication and sealing are required. Normal outside dimensions are the same as 6200 series ball bearings.

Typical mounting would be to install the **AS** model along side of a 6200 series bearing to provide the concentricity and support required. Oil or grease lubrication must be provided along with seals to retain lubricant.

The outer race has a positive r6 tolerance to give a press fit in a H7 housing. The outer race used must be strong enough not to expand after assembly.

The inner race is keyed to the shaft (except for the size 6mm bore).

This design freewheel can accept an axial misalignment of inner and outer race, consult factory for values.

These clutches are oil dipped before shipment to prevent corrosion but must be filled before use.

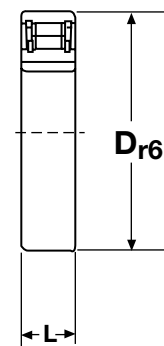
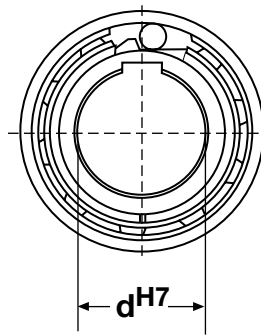

Model	Bore* d ^{H7} in./mm	Torque Capacity lb. ft.	Overrunning Speed Max. RPM		Width L in./mm	O.D. D _{r6} in./mm	Shipping Weight lb./kg
			Inner Race	Outer Race			
AS-6	.24/6	1.5	1.5	7,500	.24/6	.75/19	.02/.01
AS-8	.31/8	3	3	6,500	.31/8	.94/24	.04/.02
AS-10	.39/10	5	5	5,200	.35/9	1.18/30	.07/.03
AS-12	.47/12	10	10	4,800	.39/10	1.26/32	.09/.04
AS-15	.59/15	10	10	4,300	.43/11	1.38/35	.11/.05
AS-20	.79/20	30	30	3,300	.55/14	1.85/47	.26/.12
AS-25	.98/25	41	41	2,900	.59/15	2.05/52	.31/.14
AS-30	1.18/30	66	66	2,400	.63/16	2.44/62	.49/.22
AS-35	1.38/35	106	106	2,000	.67/17	2.83/72	.68/.31
AS-40	1.57/40	137	137	1,800	.71/18	3.15/80	.86/.39
AS-45	1.77/45	161	161	1,600	.75/19	3.35/85	.97/.44
AS-50	1.97/50	170	170	1,500	.79/20	3.54/90	1.08/.49
AS-55	2.17/55	227	227	1,300	.83/21	3.94/100	1.46/.66
AS-60	2.36/60	375	375	1,100	.87/22	4.33/110	1.79/.81
AS-80	3.15/80	784	784	900	1.02/26	5.51/140	3.11/1.41

Note

*AS-6 without keyway. AS-8 through 12 keyways to DIN 6885.1. Other sizes to DIN 6885.3.

Model FSR Freewheel Clutches

The **FSR** Model is a general purpose freewheel clutch suitable for use in overrunning, indexing or backstopping applications.

They are provided with a hub which has been ground as a mounting surface.

They include a keyseat and snap ring groove to secure mounting items.

The shaft the unit is mounted on must extend through the full length of the clutch and must be held to the recommended size limits because the sleeve bearings used in the outer race rides on the shaft.

The keyseat on the shaft used must not extend into the sleeve bearing area to prevent damage to the bearing.

Model	Max Bore in.	Torque Capacity lb. ft.	Overrunning Speed Max. RPM		Shipping Weight lb.
			Inner Race	Outer Race	
3	.50	40	1,950	900	1
5	.687	110	1,950	900	2
6	.875	300	1,950	750	3
8	1.125	450	1,650	600	5
10	1.375	675	1,250	350	6
12	1.625	1,350	1,500	350	9
14	1.875	1,600	950	250	15
16	2.187	1,800	950	250	15

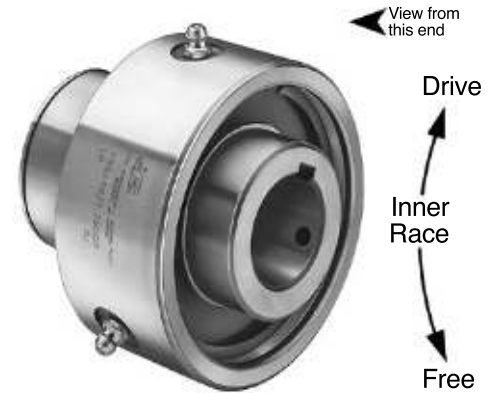

Right Hand rotation shown.
(Left Hand opposite.)
Specify direction of rotation when ordering.

Dimensions (inches)						
Model	A	B	C	D	E	F
3	1.88	1.63	.875/.874	.69	.70	.81
5	2.75	2.00	1.250/1.249	1.25	1.00	1.00
6	3.19	2.88	1.375/1.374	1.56	1.38	1.31
8	3.56	3.25	1.750/1.749	1.75	1.62	1.44
10	3.50	3.75	2.250/2.249	1.75	2.03	1.44
12	3.88	4.44	2.500/2.499	1.94	2.38	1.44
14	4.38	5.50	2.875/2.874	2.19	3.00	1.75
16	4.38	5.50	3.250/3.249	2.19	3.00	1.75

Model	G	H	J	L ₁	N
3	.500	.94	.715/.720	RS 87	.22
5	.562	1.63	.900/.905	RS 125	.25
6	.937	1.69	1.125/1.220	RS 137	.18
8	1.00	1.88	1.315/1.320	RS 175	.25
10	.94	1.81	1.340/1.345	RS 225	.25
12	1.19	2.13	1.311/1.321	RS 250	.31
14	1.34	2.25	1.625/1.630	RS 287	.31
16	1.44	2.25	1.650/1.655	RS325	.31

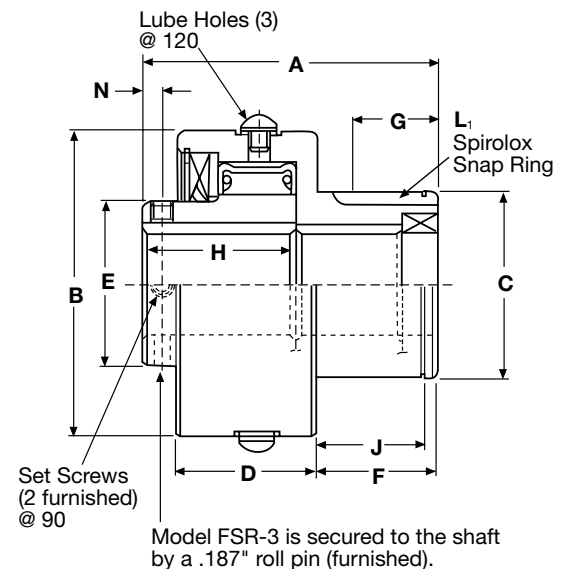

The Power Of One, The Strength Of Many.

OTHER PRODUCT SOLUTIONS FROM
ALTRA INDUSTRIAL MOTION

WWW.ALTRAMOTION.COM

Our comprehensive product offerings include various types of clutches and brakes, overrunning clutches, engineered bearing assemblies, gearing and gear motors along with linear products, belted drives, couplings and limit switches. With thousands of product solutions available, Altra provides true single source convenience while meeting specific customer requirements. Many major OEMs and end users prefer Altra products as their No. 1 choice for performance and reliability.



ELECTRIC CLUTCHES AND BRAKES

Inertia Dynamics
Matrix
Stromag
Warner Electric



HEAVY DUTY CLUTCHES AND BRAKES

Industrial Clutch
Stromag
Svendborg Brakes
Twiflex
Wichita Clutch



OVERRUNNING CLUTCHES

Formsprag Clutch
Marland Clutch
Stieber



ENGINEERED COUPLINGS AND UNIVERSAL JOINTS

Ameridrives
Bibby Turboflex
Guardian Couplings
Huco
Lamiflex Couplings
Stromag
TB Wood's



GEAR DRIVES

Bauer Gear Motor
Boston Gear
Delroyd Worm Gear
Nuttall Gear



GEAR MOTORS

Bauer Gear Motor



POWER TRANSMISSION COMPONENTS

LINEAR ACTUATORS AND CONTROLS

Warner Linear



ENGINEERED BEARING ASSEMBLIES

Kilian



AIR MOTORS

Huco



BELTED DRIVES AND SHEAVES

TB Wood's



GEARED CAM LIMIT SWITCHES

Stromag

Marland Clutch Facilities

North America

USA

23601 Hoover Road
Warren, MI 48089 - USA
1-800-216-3515

*Roller Ramp and Sprag Type
Overrunning Clutches
and Backstops*

Europe

Germany

Hatschekstraße 36
69126 Heidelberg - Germany
+49 (0) 6221-30470

*Overrunning Clutches
and Holdbacks*

Asia Pacific

Australia

+61 2 9894 0133

China

+86 21 5169-9255

Hong Kong

+852 2615 9313

Singapore

+65 6487 4464

Taiwan

+886 2 2577 8156

Thailand

+66 2322 5527

The Brands of Altra Industrial Motion

Couplings

Ameridrives

www.ameridrives.com

Bibby Turboflex

www.bibbyturboflex.com

Guardian Couplings

www.guardiancouplings.com

Huco

www.huco.com

Lamiflex Couplings

www.lamiflexcouplings.com

Stromag

www.stromag.com

TB Wood's

www.tbwoods.com

G geared Cam Limit Switches

Stromag

www.stromag.com

Electric Clutches & Brakes

Inertia Dynamics

www.idicb.com

Matrix

www.matrix-international.com

Stromag

www.stromag.com

Warner Electric

www.warnerelectric.com

Linear Products

Warner Linear

www.warnerlinear.com

Engineered Bearing Assemblies

Kilian

www.kilianbearings.com

Heavy Duty Clutches & Brakes

Industrial Clutch

www.indclutch.com

Twiflex

www.twiflex.com

Stromag

www.stromag.com

Svendborg Brakes

www.svendborg-brakes.com

Wichita Clutch

www.wichitaclutch.com

Belted Drives

TB Wood's

www.tbwoods.com

Gearing

Bauer Gear Motor

www.bauergears.com

Boston Gear

www.bostongear.com

Delroyd Worm Gear

www.delroyd.com

Nuttall Gear

www.nuttallgear.com

Overrunning Clutches

Formsprag Clutch

www.formsprag.com

Marland Clutch

www.marland.com

Stieber

www.stieberclutch.com

Neither the accuracy nor completeness of the information contained in this publication is guaranteed by the company and may be subject to change in its sole discretion. The operating and performance characteristics of these products may vary depending on the application, installation, operating conditions and environmental factors. The company's terms and conditions of sale can be viewed at <http://www.altramotion.com/terms-and-conditions/sales-terms-and-conditions>. These terms and conditions apply to any person who may buy, acquire or use a product referred to herein, including any person who buys from a licensed distributor of these branded products.

©2018 by Marland Clutch LLC. All rights reserved. All trademarks in this publication are the sole and exclusive property of Marland Clutch LLC or one of its affiliated companies.